

Screwdriver Bits

Insert Bit



Item #	Code	Description	Stock*
1-0	TIP	1" #0 Phillips	A
1-1	TIP	1" #1 Phillips	Y
1-2	TIP	1" #2 Phillips	Y
1-3	TIP	1" #3 Phillips	Y
1-S56	TIP	1" #5-6 Slotted	A
1-S	TIP	1" #6-8 Slotted	Y
1-S810	TIP	1" #8-10 Slotted	A
1-S1214	TIP	1" #12-14 Slotted	A
SQR1	TIP	1" #1 Square Drive	Y
SQR2	TIP	1" #2 Square Drive	Y
SQR3	TIP	1" #3 Square Drive	Y

Power Bit



Item #	Code	Description	Stock*
SQ2+-1	TIP	2" #1 Phillips	Y
SQ2+-2	TIP	2" #2 Phillips	Y
SQ2+-3	TIP	2" #3 Phillips	Y
3+-1	TIP	3" #1 Phillips	A
3+-2	TIP	3" #2 Phillips	Y
3.5+-3	TIP	3½" #3 Phillips	Y
4+-1	TIP	4" #1 Phillips	A
4+-2	TIP	4" #2 Phillips	Y
4+-3	TIP	4" #3 Phillips	Y
6+	TIP	6" #2 Phillips	Y
SQ6+	TIP	6" #2 Square Drive	A

Nutsetter

- Hex shank
- Magnetic



Item #	Code	Description	Stock*
14NS	TIP	¼" Nutsetter	Y
14NS-4	TIP	¼" x 4" Nutsetter	Y
14NS-6	TIP	¼" x 6" Nutsetter	Y
516NS	TIP	⅝" Nutsetter	Y
516NS-4	TIP	⅝" x 4" Nutsetter	Y
516NS-6	TIP	⅝" x 6" Nutsetter	Y
38NS	TIP	⅜" Nutsetter	Y
38NS-4	TIP	⅜" x 4" Nutsetter	Y
38NS-6	TIP	⅜" x 6" Nutsetter	Y
716NS	TIP	⅞" Nutsetter	Y

Extra-Long Square Drive Bit

- ¼" Hex shank
- Magnetic

Item #	Code	Description	Stock*
5504-PC	PC	XL Square Drive Bit	Y



Torx® Bit

Hex Drive



Item #	Code	Size	Dia.	Stock*
TORXT10	TIP	T-10	¼"	Y
TORXT15	TIP	T-15	¼"	Y
TORXT20	TIP	T-20	¼"	Y
TORXT25	TIP	T-25	¼"	Y
TORXT30	TIP	T-30	¼"	Y
TORXT40	TIP	T-40	¼"	Y

Tamperproof Bits & Tools

Spanner Bit

Hex Shank



Item #	Code	Size	Dia.	Stock*
14SPAN4	TIP	#4	¼"	A
516SPAN4	TIP	#4	⅝"	A
14SPAN6	TIP	#6	¼"	Y
516SPAN6	TIP	#6	⅝"	A
14SPAN8	TIP	#8	¼"	Y
516SPAN8	TIP	#8	⅝"	A
14SPAN10	TIP	#10	¼"	Y
516SPAN10	TIP	#10	⅝"	A
14SPAN12	TIP	#12	¼"	A
516SPAN12	TIP	#12	⅝"	A
14SPAN14	TIP	#¼	¼"	A
516SPAN14	TIP	#¼	⅝"	A



Torx® Bit

Hex Drive



Item #	Code	Size	Dia.	Stock*
TAMTORXT7	TAM	T-7	¼"	A
TAMTORXT8	TAM	T-8	¼"	A
TAMTORXT9	TAM	T-9	¼"	A
TORXT10	TAM	T-10	¼"	Y
TAMTORXT27	TAM	T-27	¼"	Y
TAMTORXT45	TAM	T-45	⅝"	A
TAMTORXT50	TAM	T-50	⅝"	A



Socket Pin-Head Bit

Hex Drive



Item #	Code	Size	Diameter	Stock*
6B.332	TAM	⅜"	¼"	A
6B.18	TAM	⅛"	¼"	A
6B.532	TAM	⅝"	¼"	A
6B.316	TAM	⅜"	¼"	A
6B.732	TAM	⅞"	¼"	A

Phillips Pin-Head Bit

Hex Drive



Item #	Code	Size	Diameter	Stock*
2B.2	TAM	#2	¼"	A
2B.3	TAM	#3	¼"	A

Tri-Wing® Bit

Hex Drive



Item #	Code	Size	Diameter	Stock*
3B.W1	TAM	W1	¼"	A
3B.W2	TAM	W2	¼"	A
3B.W3	TAM	W3	¼"	A
3B.W4	TAM	W4	¼"	A
3B.W5	TAM	W5	¼"	A

*Y = stock item; A = readily available by order

Tamperproof Bits & Tools



Tamperproof Screw Company Screws & Tools - Available To Order

Screw Head Types



Snake Eyes® Spanners

The original Snake Eyes® spanner requires matching drive bit, reducing the chances of unauthorized removal. Available in 18-8 stainless steel in a wide range of sizes and head styles. Some machine screws available in brass. Nuts are zinc alloy.



Phillips Pin-Head

Traditional Phillips drive with tamper-resistant pin added for security. Easy to drive and remove with matching tool. (Cannot be removed with Phillips screwdriver.) Available in machine and sheet metal screws with flat or pan head design.



One-Way Slotted

Popular design installs with standard screwdriver. Reverse side cammed out to prevent unauthorized removal. Machine and sheet metal screws available in round, truss or oval head designs. Sex bolts also available.



OPSIT® Reverse Thread

Opsit is a reverse thread sheet metal screw that installs counter-clockwise, thus, tightening if removal is attempted. Available with a low-profile truss head and Tri-Wing drive.



Socket Pin-Head

Engineered for a high degree of tamper resistance offering positive engaging, high torque transmission while resisting cam-out and tool wear. Available in button and flat head design or set screws (special order). Matching drive bit required for installation and removal.



Torx® Pin-Head

Maximum torque transfer and positive tool engagement means easier drive installation with less pressure and slippage. Torx Pin-Head offers a high degree of security and requires matching drive bit. Available in button and flat head machine screws and button, flat and pan head design sheet metal screws.



Tri-Wing®

Economical Tri-Wing tamper-resistant screws are the common choice for high volume assembly operations while offering a minimal degree of security. Machine and sheet metal screws are offered in a pan head design and Opsit reverse thread.



TP3 Triangular

New trilobular drive offers a high degree of security. Requires matching tool bit.

Thread Styles



Sheet Metal A or AB

Thread forming screw with locating point.



Machine MS

Machine screw with standard thread and straight sheared point.



Self-Drilling

Type AB thread with a 410 heat treated stainless steel, #2 self-drilling point.

Head Styles



Pan

Features a low profile, large diameter head with a high-edged crown for increased strength.



Flat

Installs flush with countersunk materials for a clean appearance.



Truss

Low profile offers added security. Large diameter head for increased fastening strength.



Round

One-way screws only. Features a high crown with a deep recess and a smaller diameter head than truss or pan head designs.



Oval

Use where countersink installation is desired. Rounded head offers deep recess and is visible just above the surface.



Button

Use for general purposes. Features a lower crown and shallower recess than round head design.

Magnetic Hand Driver

Item #	Code	Description	Stock*
MHD14	TAM	¼" Hex Shank	A
MHD516	TAM	⅝" Hex Shank	A

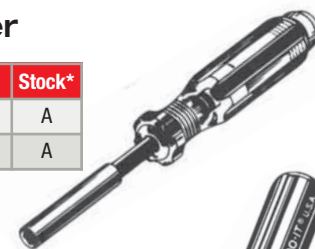

Un-Do-It® One-Way Removal Tool

One-Ways are easily installed with a standard screwdriver. Removal may be possible with the Un-Do-It removal tool.

Item #	Code	Description	Stock*
5.804	TAM	#804 (Screw Sizes 6-8)	A
5.807	TAM	#807 (Screw Sizes 10-12)	A
5.810	TAM	#810 (Screw Sizes ¼)	A



Spanner Security Screw Kit

Contains 20 most-wanted sizes of machine and wood/metal Snake Eyes spanner security screws. A total of 1,000 stainless steel screws in sizes 6, 8 and 10, ½" to 1" lengths, with flat heads and pan heads. Includes three special matching drivers & sturdy steel storage box.

Torx® Security Screw Kit

Contains 20 popular sizes of machine and wood/metal Torx security screws. A total of 1,000 stainless steel screws in sizes 6, 8 and 10, ½" to 1" lengths, with flat heads and button heads. Includes four matching driver bits, magnetic hand driver & sturdy steel storage box.

Item #	Code	Description	Stock*
1.1000	TAM	Spanner Screw Kit	A
4.1000	TAM	Torx Screw Kit	A

Screwdriving Bit Sets & Tools

31 Piece Security Tool Kit



Includes:

- Spanner bits #4, #6, #8, #10
- TORX® bits TR7, TR8, TR9, TR10, TR15, TR20, TR25, TR27, TR30, TR40
- Socket head bits 3/32", 7/64", 1/8", 9/64", 5/32", 3/16", 7/32", 1/4"
- Square bits 1, 2
- Phillips security bits 2, 3
- Phillips bit 1
- Slotted bit 8
- 1/4" Socket adapter
- 1/4" Magnetic bit holder
- Magnetic hand driver
- Heavy-duty plastic case



Item #	Code	Description	Stock*
2100-TIP	TIP	31 Piece Security Tool Kit	Y

Masonry Drill & Drive Tool Kit



For installation of concrete screws.

Includes:

- Drive tube
- 1/4" Drive nutsetter
- 5/16" Drive nutsetter
- Holder for Phillips bits
- Drill holder
- L-Hex key
- #2 Phillips bit
- #3 Phillips bit
- Heavy-duty plastic case



Item #	Code	Description	Stock*
625-QUA	TAP	Masonry Drill/Drive Kit	Y

15 Piece Self-Feeding Bit Clip



- (15) #2 Phillips head bits

Item #	Code	Description	Stock*
BCLIP15	BOS	15 Piece Bit Clip	Y



6-in-One Screwdriver

- 1/4" Slotted bit
- 3/16" Slotted bit
- #1 x #2 Phillips bit
- 3/16" Nut driver



Item #	Code	Description	Stock*
6IN1-BLUE	TIP	Blue Multi-bit Screwdriver	Y
6IN1-GREEN	TIP	Green Multi-bit Screwdriver	Y



15-in-One Ratchet Screwdriver

- 1/8" Slotted x #0 Phillips bit
- 1/4" Slotted x 3/16" slotted bit
- 1/4" Slotted x #2 Phillips bit
- 5/32" Slotted x #3 Phillips bit
- #1 x #2 Phillips bit
- T13 x T20 Torx® bit
- S1 x S2 square bit



Item #	Code	Description	Stock*
15IN1-RATCH	TIP	15-In-1 Ratchet Screwdriver	Y



3" Mega Magnetic Bit Holder

Two powerful magnets create 40x the pulling power of ordinary magnetic bit holders.

- Works with all 1" insert bits
- 1/4" Hex shank

Item #	Code	Description	Stock*
45834	IVY	Mega Magnetic Bit Holder	Y



1/4" Hex Drive Magnetic Bit Holder

- One-piece stainless steel construction with C-ring retainer

Item #	Code	Description	Stock*
45098	IVY	Magnetic Bit Holder	Y



3" Hex to Square Socket Adapter

Item #	Code	Description	Stock*
2EXT-12	IVY	3" x 1/4" Hex to 1/2" Square	Y
2EXT-14	IVY	2 1/2" x 1/4" Hex to 1/4" Square	Y
2EXT-38	IVY	2 1/2" x 1/4" Hex to 3/8" Square	Y

Acoustical Eye Lag Driver



- 1/4" Hex drive for quick installation of eye lag hanger bolts

Item #	Code	Description	Stock*
LAG.DRIVER	IVY	Acoustical Lag Driver	Y



Tension Pin

Item #	Code	Description	Stock*
TP118PACK	IVY	1 1/8" Tension Pin - 5 lb.	Y

Phillips® Drywall Screw Setter



- 1" #2 Phillips head

Item #	Code	Description	Stock*
DRYWALLDRIVER	IVY	Drywall Screw Setter	Y

Screwdriving Bit Sets & Tools

Milwaukee



38 Piece Insert Bit Set

- 6" Quik-lok all-hex extension
- Quik-lok all-hex chuck
- Compact screw guide
- (5) Phillips bit tips
- (4) Square recess bit tips
- (2) Slotted bit tips
- (7) Power groove bits
- (6) Six double-ended bits
- (2) Socket adaptors
- (2) Magnetic nutsetters
- (7) Titanium shank drill bits
- Storage case

Item #	Code	Description	Stock*
48-32-1500	MIL	32 Piece Bit Set	Y

20 Piece Insert Bit Set

Set includes 19 of the most commonly used Phillips, square drive, Torx® and slotted screwdriver bits, magnetic drive guide and magnetic storage case.



Item #	Code	Description	Stock*
48-32-1700	MIL	20 Piece Bit Set	Y



12 Piece Shockwave™ Drive Guide Set

Milwaukee® Shockwave Impact Duty™ Drive Guide Sets are engineered for extreme durability and up to 10x life.

- 1" Phillips Bit: (2) P2, (1) P3
- 1" Square Bit: (1) SQ2
- 1" Slotted Bit: (1) SL 3/16", (1) SL 1/4"
- 1" Torx® Bit: (1) T15, (1) T20, (1) T25
- 1" ECX Bits: (1) ECX #1, (1) ECX #2
- (1) 3" Magnetic Shockwave Drive Guide

Item #	Code	Description	Stock*
48-32-4507	MIL	12 Piece Bit Set	Y

BOSCH



42 Piece Screwdriving Bit Set

- 1" Hex insert bits: (2) #1, (10) #2, (2) #3
- 1" Square insert bits: (1) #1, (6) #2
- 1" Slotted insert bits: (1) 6-8, (1) 8-10, (1) 10-12
- 2" Hex power bits: (2) #1, (4) #2, (2) #3
- 2" Square power bits: (4) #2
- 2" Slotted power bits: (1) 6-8, (1) 8-10
- 1/4" Nutsetter & 5/16" nutsetter
- Finder guide

Item #	Code	Description	Stock*
T4042	BOS	42 Piece Bit Set	Y



9 Piece Tapcon Set

Includes (1) P2 power bit, (1) P3 power bit, (1) 5/16" hex socket, (1) 1/4" hex socket, (1) 3/16" drill bit, (1) 5/32" drill bit, (1) drive sleeve, (1) hex key, and Brute Tough™ case.

Item #	Code	Description	Stock*
TC900	BOS	9 Piece Tapcon Set	Y

14 Piece Magnetic Drive Guide Set

- 1/4" Hex shank
- (2) Magnetic drive guides
- (6) #2 Phillips
- (2) #8 and #10 slotted
- (3) #2 Square recess bits
- Case



Item #	Code	Description	Stock*
DW2097CS	DEW	14 Piece Bit Set	Y

DEWALT



21 Piece Screwdriving Set

- 1" Slotted bit tips: in #6, #8, #10
- Square recess bit tips: #1, #2, #3
- 2" Phillips power bit
- 2" Square recess power bit
- 1/4" and 5/16" nutdrivers
- Magnetic bit tip holder
- Case

Item #	Code	Description	Stock*
DW2161	DEW	21 Piece Bit Set	Y



28 Piece Impact Ready Screwdriving Set

Includes most common impact driver accessories, including a variety of Phillips, square drive and flat head bits, drivers, a magnetic tip holder and various double and single sided tips.

Item #	Code	Description	Stock*
DW2149	DEW	28 Piece Bit Set	Y



37 Piece Screwdriving Set

- 1" Slotted bit tips: in #6, #8, #10
- 1" Square recess bit tips: #1, #2, #3
- 1" insert bit tips: #1, #2, #3
- #2 Phillips/#8 slotted double-ended bit
- 3 1/2" Phillips power bit
- 3 1/2" Square recess power bit
- 1/4" and 5/16" nutdrivers
- Magnetic drive guide and case

Item #	Code	Description	Stock*
DW2163	DEW	37 Piece Bit Set	Y

Drywall Screws



Drywall - Fine Thread

- Attachment of gypsum board and other materials to 25 gauge steel stud construction
- Phillips bugle head
- Phosphate coated (Zinc available)

Item #	Code	Size	Std. Case	Std. Pack	Stock*
SP114-5	DWS	#6 x 1¼	—	5 lb.	Y
SP114CASE	DWS	#6 x 1¼	8M	1,000	A
SP158-5	DWS	#6 x 1⅝	—	5 lb.	Y
SP158CASE	DWS	#6 x 1⅝	6M	—	A
SP2-5	DWS	#6 x 2	—	5 lb.	Y
SP2CASE	DWS	#6 x 2	3.5M	—	A
SP214-5	DWS	#6 x 2¼	—	350	Y
SP214CASE	DWS	#6 x 2¼	3M	—	Y
SP212-5	DWS	#8 x 2½	—	5 lb.	Y
SP212CASE	DWS	#8 x 2½	2.5M	—	A
SP3CASE	DWS	#8 x 3	2M	200	A
SP312CASE	DWS	#10 x 3½	1.5M	200	A
SP4-5	DWS	#10 x 4	—	5 lb.	Y
SP4CASE	DWS	#10 x 4	1M	200	A
SP412CASE	DWS	#10 x 4½	3M	150	A
SP5-5	DWS	#10 x 5	—	5 lb.	Y
SP5CASE	DWS	#10 x 5	1M	150	A
SP6CASE	DWS	#10 x 6	1M	—	A



Drywall - Coarse Thread

- Attachment of gypsum board and other materials to wood stud construction
- Phillips bugle head
- Phosphate coated (Zinc available)

Item #	Code	Size	Std. Case	Std. Pack	Stock*
HT114-5	DWS	#6 x 1¼	—	5 lb.	Y
HT114CASE	DWS	#6 x 1¼	8M	—	Y
HT158-5	DWS	#6 x 1⅝	—	5 lb.	Y
HT158CASE	DWS	#6 x 1⅝	5M	—	Y
HT2-5	DWS	#6 x 2	—	5 lb.	Y
HT2CASE	DWS	#6 x 2	3.5M	—	Y
HT212-5	DWS	#8 x 2½	—	5 lb.	Y
HT212CASE	DWS	#8 x 2½	2.5M	—	Y
HT3-5	DWS	#8 x 3	—	5 lb.	Y
HT3CASE	DWS	#8 x 3	2M	—	Y
HT312	DWS	#10 x 3½	—	200	A
HT312CASE	DWS	#10 x 3½	1M	—	Y
HT4-5	DWS	#10 x 4	—	5 lb.	Y
HT4CASE	DWS	#10 x 4	1M	—	Y
HT412	DWS	#10 x 4½	1M	150	A
HT5	DWS	#10 x 5	1M	150	A
HT6	DWS	#10 x 6	1M	—	A



Trim Head

- Finish work to 25 gauge steel
- #1 square drive
- Phosphate coated

Item #	Code	Size	Std. Case	Std. Pack	Stock*
SPTHSQ158-5	DWS	#6 x 1⅝	—	5 lb.	Y
SPTHSQ158	DWS	#6 x 1⅝	5M	—	A
SPTHSQ214-5	DWS	#6 x 2¼	—	5 lb.	Y
SPTHSQ214	DWS	#6 x 2¼	3M	—	A
SPTHSQ3-5	DWS	#8 x 3	—	5 lb.	Y
SPTHSQ3	DWS	#8 x 3	2M	—	A



Framing - X Fine Thread

- 25 gauge application where additional holding power is required
- Phillips pan head
- Zinc and yellow coated

Item #	Code	Size	Std. Case	Std. Pack	Stock*
SPFR716	DWS	#7 x 7/16	15M	1.5M	A



Laminating

- Temporary gypsum to gypsum fastening
- Phillips bugle head
- Phosphate coated

Item #	Code	Size	Std. Case	Std. Pack	Stock*
RR112PACK	DWS	#10 x 1½	—	5 lb.	Y
RR112	DWS	#10 x 1½	5M	—	A

Deck Screws



Premium Decking

- Square drive
- Nibs under head
- Cutter point
- Easy draw shank
- 1000 hour salt spray test

Item #	Code	Size	Std. Case	Std. Pack	Stock*
XT114	DWS	#8 x 1¼	8M	1,000	A
XT112	DWS	#8 x 1½	—	5 lb.	A
XT112CASE	DWS	#8 x 1½	5M	—	Y
XT158-5	DWS	#8 x 1⅝	—	5 lb.	Y
XT158CASE	DWS	#8 x 1⅝	5M	—	Y
XT2-5	DWS	#8 x 2	—	5 lb.	Y
XT2CASE	DWS	#8 x 2	3.5M	—	Y
XT212-5	DWS	#8 x 2½	—	5 lb.	Y
XT212CASE	DWS	#8 x 2½	2.5M	—	Y
XT3-5	DWS	#8 x 3	—	5 lb.	Y
XT3CASE	DWS	#8 x 3	2M	—	Y
XT312-5	DWS	#10 x 3½	—	200	Y
XT312CASE	DWS	#10 x 3½	1.5M	—	Y

*Y = stock item; A = readily available by order

Screw Fasteners For Senco Duraspin Tools



#2 Phillips Drive, Bugle Head Screw

Item #	Code	Size	Point	Finish	Thread	Qty	Stock*
06A162P-1M	SEN	#6 x 1 5/8"	Sharp	Grey Phosphate	Coarse	1M	Y
06A162W	SEN	#6 x 1 5/8"	Sharp	Weatherex II	Coarse	1M	A
06B162P-1M	SEN	#6 x 1 5/8"	Sharp	Grey Phosphate	Fine	1M	Y
06C162C	SEN	#6 x 1 5/8"	Sharp	Grey Phosphate	Fine	1M	A
07A200P	SEN	#7 x 2"	Sharp	Grey Phosphate	Coarse	1M	A
06A125P-1M	SEN	#6 x 1 1/4"	Sharp	Grey Phosphate	Coarse	1M	Y
06B125P	SEN	#6 x 1 1/4"	Sharp	Grey Phosphate	Fine	1M	A
06C125C	SEN	#6 x 1 1/4"	Self-Drill	Clear	Fine	1M	A

#2 Square Drive, Flat Head Screw - Coarse

Item #	Code	Size	Point	Finish	Qty	Stock*
08T125W-1M	SEN	#8 x 1 1/4"	Spoon	Weatherex II	1M	Y
08F150Y-1M	SEN	#8 x 1 1/2"	Sharp	Yellow Zinc	1M	Y
08F175Y	SEN	#8 x 1 3/4"	Sharp	Yellow Zinc	1M	A
08D175W-1M	SEN	#8 x 1 3/4"	Type 17 Cut	Weatherex II	1M	Y
08L175YB	SEN	#8 x 1 3/4"	Type 17 Cut	Yellow Zinc	1M	A
08F200Y-1M	SEN	#8 x 2"	Sharp	Yellow Zinc	1M	Y
08D200W-1M	SEN	#8 x 2"	Type 17 Cut	Weatherex II	1M	Y
08F250Y	SEN	#8 x 2 1/2"	Sharp	Yellow Zinc	800	A
08D250S	SEN	#8 x 2 1/2"	Type 17 Cut	Stainless Steel	800	A
08D250W-800	SEN	#8 x 2 1/2"	Type 17 Cut	Weatherex II	800	Y
08F300Y	SEN	#8 x 3"	Sharp	Yellow Zinc	800	A
08D300W	SEN	#8 x 3"	Type 17 Cut	Weatherex II	800	A
09D300S	SEN	#9 x 3"	Type 17 Cut	Stainless Steel	800	A
10F200Y	SEN	#10 x 2"	Sharp	Yellow Zinc	800	A

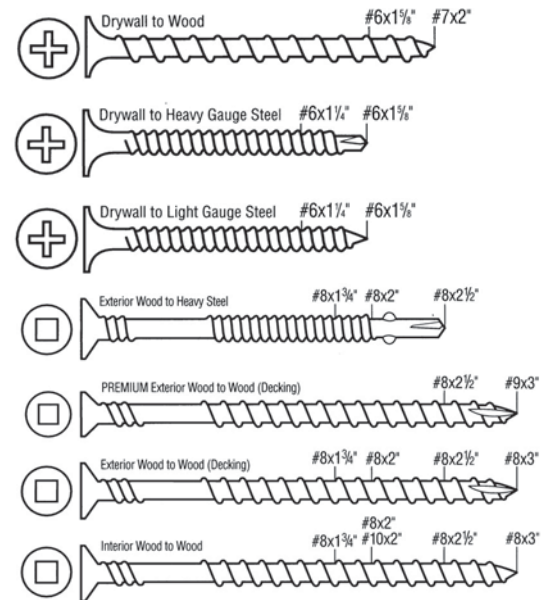

These tools use the above screws

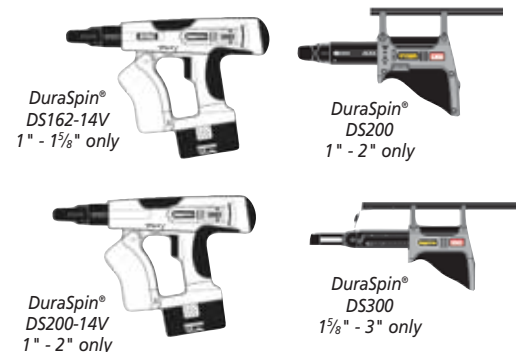

Drilling Capacity for Self-Drilling Screws









STANDARD FASTENERS			
Application	What to Use	Diameter	Recommended Material Thickness
Light Gauge Metals	Type 2	No. 6	.035 - .090
		No. 8	.035 - .100
		No. 10	.035 - .110
Medium Gauge Metals	Type 3	No. 8	.100 - .140
		No. 10	.110 - .175
		No. 12	.110 - .210
		1/4"	.110 - .250

STANDARD FASTENERS			
Application	What to Use	Diameter	Recommended Material Thickness
Heavier Gauge Metals	Type 4	No. 12	.175 - .210
		1/4"	.175 - .250
	Special Type 4	No. 12	.210 - .375
Drill-It		No. 12	.250 - .500

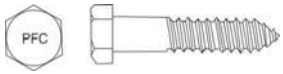
*Y = stock item; A = readily available by order

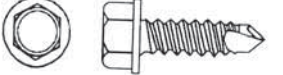

Screws

Many sizes in stock; all sizes available.

	Description
	Machine Screw • Round head • Slotted steel/zinc
	Cap Screw • Grade 5 steel/zinc
	Hex Lag Screw • Steel/zinc
	Sheet Metal Screw • Hex washer head • Slotted steel/zinc
	Sheet Metal Screw • Pan head Phillips • Steel/zinc
	Sheet Metal Screw • Flat head Phillips • Steel/zinc
	Self-Drilling Screw • Hex washer head • Steel/zinc
	Self-Drilling Screw • Phillips pan Head • Steel/zinc

Bolts

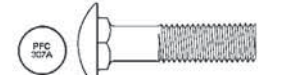
Many sizes in stock; all sizes available.

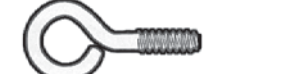

	Description
	Carriage Bolt • Steel/zinc
	Hanger Bolt • Steel/zinc
	Eye Bolt • Steel/zinc • No nut

PRODUCTS NOT LISTED?

All of the products we sell are not listed in this catalog. If you don't find everything you need, PLEASE CALL US—WE CAN HELP!

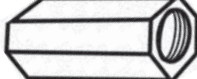

Nuts

Many sizes in stock; all sizes available.

	Description
	Hex Rod Coupling Nut • Steel/zinc
	Hex Finish Nut • Steel/zinc
	Nylon Insert Lock Nut • Steel/zinc

Washers

Many sizes in stock; all sizes available.

	Description
	Split Lock Washer • Steel/zinc
	Fender Washer • Steel/zinc
	Flat Washer • Steel/zinc

See our complete line of nail & tool bags on pages 95-97



*Y = stock item; A = readily available by order

Anchors



Power-Bolt™

Base Material: Concrete, Block, Brick, Stone
Size Range: ¼" x 1" to ¾" x 8¼"
Anchor Material: Carbon Steel & Type 304 Stainless Steel

The Power-Bolt anchor is a heavy-duty, sleeve anchor that is vibration resistant and removable. It is available with a finished hex head or flat head with a hex key insert.

Carbon Steel Hex Head Power-Bolt

Carbon steel Power-Bolt anchors are manufactured using a Grade 5 bolt. They are plated with a commercial bright zinc finish and have a supplementary chromate treatment in accordance with ASTM Specification B 633.

Item #	Code	Size†	Drill Dia.	Min. Depth	Std. Box	Std. Ctn.	Stock*
6900	POW	¼" x 1"	¼"	7/8"	100	600	A
6902	POW	¼" x 1¾"	¼"	1¼"	100	600	A
6906	POW	¼" x 3"	¼"	1¼"	100	600	A
6907	POW	⅝" x 1¾"	⅝"	1½"	100	600	A
6908	POW	⅝" x 2½"	⅝"	1½"	50	300	A
6909	POW	⅝" x 3½"	⅝"	1½"	50	300	A
6910	POW	⅜" x 2¼"	⅜"	2"	50	300	Y
6913	POW	⅜" x 3"	⅜"	2"	50	300	Y
6914	POW	⅜" x 3½"	⅜"	2"	50	300	Y
6916	POW	⅜" x 4"	⅜"	2"	50	300	Y
6930	POW	½" x 2¾"	½"	2½"	50	200	Y
6932	POW	½" x 3¾"	½"	2½"	25	150	Y
6934	POW	½" x 4¾"	½"	2½"	25	150	Y
6936	POW	½" x 5¾"	½"	2½"	25	150	Y
6940	POW	⅝" x 3"	⅝"	2¾"	20	120	A
6942	POW	⅝" x 4"	⅝"	2¾"	15	90	A
6944	POW	⅝" x 5"	⅝"	2¾"	15	90	A
6945	POW	⅝" x 6"	⅝"	2¾"	15	90	A
6947	POW	⅝" x 8½"	⅝"	2¾"	10	40	A
6950	POW	¾" x 3¼"	¾"	3"	15	90	A
6952	POW	¾" x 4¼"	¾"	3"	10	60	A
6954	POW	¾" x 5¼"	¾"	3"	10	60	A
6956	POW	¾" x 7¼"	¾"	3"	10	40	A
6957	POW	¾" x 8¼"	¾"	3"	10	40	A

†Published length is measured from below the washer to the end of the anchor.



*Y = stock item; A = readily available by order



CODE LISTED
ICC-ES ESR-2818

CODE LISTED
ICC-ES ESR-2966

Power-Stud+™ SD1

Base Material: Normal-weight Concrete, Structural Sand-Lightweight Concrete, Concrete over Metal Deck, Grout-filled Masonry
Size Range: ¼" x 1¾" to 1¼" x 12"
Anchor Material: Zinc-plated carbon steel body and expansion clip, with nut and washer

The Power-Stud+ SD1 anchor is a fully threaded, torque-controlled wedge expansion anchor that is designed for consistent performance in cracked and uncracked concrete.

Item #	Code	Size†	Min. Embed.	Thread Length	Std. Box	Std. Ctn.	Stock*
7400SD1	POW	¼" x 1¾"	1⅞"	¾"	100	500	Y
7402SD1	POW	¼" x 2¼"	1⅞"	1¼"	100	500	Y
7404SD1	POW	¼" x 3¼"	1⅞"	2¼"	100	500	Y
7410SD1	POW	⅜" x 2¼"	1⅞"	1¼"	50	250	Y
7412SD1	POW	⅜" x 2¾"	1⅞"	1⅝"	50	250	A
7413SD1	POW	⅜" x 3"	1⅞"	1⅞"	50	250	Y
7414SD1	POW	⅜" x 3½"	1⅞"	2⅜"	50	250	Y
7415SD1	POW	⅜" x 3¾"	1⅞"	2⅝"	50	250	Y
7416SD1	POW	⅜" x 5"	1⅞"	3⅞"	50	250	Y
7417SD1	POW	⅜" x 7"	1⅞"	5⅞"	50	200	Y
7420SD1	POW	½" x 2¾"	2¼"	1⅞"	50	200	Y
7422SD1	POW	½" x 3¾"	2¼"	2⅜"	50	200	Y
7423SD1	POW	½" x 4½"	2¼"	3⅞"	50	200	Y
7424SD1	POW	½" x 5½"	2¼"	4⅞"	50	150	Y
7426SD1	POW	½" x 7"	2¼"	5⅝"	25	100	Y
7427SD1	POW	½" x 8½"	2¼"	7⅞"	25	100	A
7430SD1	POW	⅝" x 3½"	2¾"	2"	25	100	Y
7432SD1	POW	⅝" x 4½"	2¾"	3"	25	100	Y
7433SD1	POW	⅝" x 5"	2¾"	3½"	25	100	Y
7434SD1	POW	⅝" x 6"	2¾"	4½"	25	75	Y
7436SD1	POW	⅝" x 7"	2¾"	5½"	25	75	Y
7438SD1	POW	⅝" x 8½"	2¾"	7"	25	75	Y
7439SD1	POW	⅝" x 10"	2¾"	8½"	25	75	Y
7440SD1	POW	¾" x 4¼"	3⅞"	2⅜"	20	60	Y
7441SD1	POW	¾" x 4¾"	3⅞"	2⅞"	20	60	Y
7442SD1	POW	¾" x 5½"	3⅞"	3⅝"	20	60	Y
7444SD1	POW	¾" x 6¼"	3⅞"	4⅞"	20	60	Y
7446SD1	POW	¾" x 7"	3⅞"	5⅞"	20	60	Y
7448SD1	POW	¾" x 8½"	3⅞"	6⅝"	10	40	Y
7449SD1	POW	¾" x 10"	3⅞"	8⅞"	10	30	Y
7451SD1	POW	¾" x 12"	3⅞"	10⅞"	10	30	A
7450SD1	POW	⅞" x 6"	3⅞"	2¾"	10	40	Y
7452SD1	POW	⅞" x 8"	3⅞"	4¾"	10	40	Y
7454SD1	POW	⅞" x 10"	3⅞"	6¾"	10	30	Y
7461SD1	POW	1" x 6"	4½"	2⅜"	10	30	Y
7463SD1	POW	1" x 9"	4½"	5⅞"	10	30	A
7465SD1	POW	1" x 12"	4½"	8⅞"	5	15	A
7473SD1	POW	1¼" x 9"	5⅞"	4¾"	5	15	A
7475SD1	POW	1¼" x 12"	5⅞"	7¾"	5	15	A

†The published length is the overall length of the anchor. Allow for fixture thickness plus one anchor diameter for the nut and washer thickness when selecting a length.

Anchors

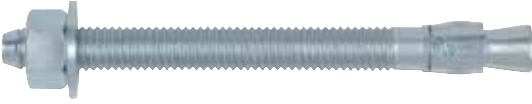

Power-Stud™

Base Material: Concrete, Grouted CMU
Size Range: ¼" x 1¾" to 1¼" x 12"
Anchor Material: Carbon Steel, Type 304 or 316 Stainless Steel, & Mechanically Galvanized Carbon Steel

The Power-Stud anchor is a one piece, fully threaded, wedge expansion anchor. Threaded, Rod Hanger and Tie-Wire versions are designed for use in solid concrete. The drill bit diameter needed for proper installation is the same as the anchor diameter.

Type 304 Stainless Steel Power-Stud

Item #	Code	Size†	Min. Embed.	Thread Length	Std. Box	Std. Ctn.	Stock*
7300	POW	¼" x 1¾"	1⅛"	¾"	100	500	A
7302	POW	¼" x 2¼"	1⅛"	1¼"	100	500	A
7304	POW	¼" x 3¼"	1⅛"	2¼"	100	500	A
7310	POW	⅜" x 2¼"	1⅝"	1¼"	50	250	A
7312	POW	⅜" x 2¾"	1⅝"	1⅝"	50	250	A
7313	POW	⅜" x 3"	1⅝"	1⅞"	50	250	A
7314	POW	⅜" x 3½"	1⅝"	2⅜"	50	250	A
7315	POW	⅜" x 3¾"	1⅝"	2⅝"	50	250	A
7316	POW	⅜" x 5"	1⅝"	3⅛"	50	250	A
7320	POW	½" x 2¾"	2¼"	1⅜"	50	200	A
7322	POW	½" x 3¼"	2¼"	2⅜"	50	200	A
7323	POW	½" x 4½"	2¼"	3⅞"	50	200	A
7324	POW	½" x 5½"	2¼"	4⅞"	50	150	A
7326	POW	½" x 7"	2¼"	5⅝"	25	100	A
7330	POW	⅝" x 3½"	2¾"	2"	25	100	A
7332	POW	⅝" x 4½"	2¾"	3"	25	100	A
7333	POW	⅝" x 5"	2¾"	3½"	25	100	A
7334	POW	⅝" x 6"	2¾"	4½"	25	75	A
7336	POW	⅝" x 7"	2¾"	5½"	25	75	A
7338	POW	⅝" x 8½"	6⅞"	7"	25	75	A
7340	POW	¾" x 4¼"	3⅞"	2⅜"	20	60	A
7341	POW	¾" x 4¾"	3⅞"	2⅞"	20	60	A
7342	POW	¾" x 5½"	3⅞"	3⅝"	20	60	A
7344	POW	¾" x 6¼"	3⅞"	4⅜"	20	60	A
7346	POW	¾" x 7"	3⅞"	5⅛"	20	60	A
7348	POW	¾" x 8½"	3⅞"	6⅝"	10	40	A
7349	POW	¾" x 10"	3⅞"	8⅞"	10	30	A
7352	POW	⅞" x 8"	3⅞"	4¾"	10	40	A
7361	POW	1" x 6"	4½"	2⅜"	10	30	A
7363	POW	1" x 9"	4½"	5⅜"	10	30	A
7365	POW	1" x 12"	4½"	8⅞"	5	15	A

Tie-Wire Power-Stud™



Item #	Code	Size†	Min. Embed.	Thread Length	Std. Box	Std. Ctn.	Stock*
7409	POW	¼" x 2"	⅜"	1⅞"	100	500	A

Galvanized Power-Stud

Item #	Code	Size†	Min. Embed.	Thread Length	Std. Box	Std. Ctn.	Stock*
7720	POW	½" x 2¾"	2¼"	1⅜"	50	200	A
7723	POW	½" x 4½"	2¼"	3⅞"	50	200	A
7724	POW	½" x 5½"	2¼"	4⅞"	50	150	A
7726	POW	½" x 7"	2¼"	5⅝"	25	100	A
7730	POW	⅝" x 3½"	2¾"	2"	25	100	A
7734	POW	⅝" x 6"	2¾"	4½"	25	75	A
7741	POW	¾" x 4¾"	3⅞"	2⅞"	20	60	A
7742	POW	¾" x 5½"	3⅞"	3⅝"	20	60	A
7748	POW	¾" x 8½"	3⅞"	6⅝"	10	40	A
7750	POW	⅞" x 6"	3⅞"	2¾"	10	40	A
7752	POW	⅞" x 8"	3⅞"	4¾"	10	40	A
7763	POW	1" x 9"	4½"	5⅜"	10	30	A

Type 316 Stainless Steel Power-Stud

Item #	Code	Size†	Min. Embed.	Thread Length	Std. Box	Std. Ctn.	Stock*
7600	POW	¼" x 1¾"	1⅛"	¾"	100	500	A
7602	POW	¼" x 2¼"	1⅛"	1¼"	100	500	A
7604	POW	¼" x 3¼"	1⅛"	2¼"	100	500	A
7610	POW	⅜" x 2¼"	1⅝"	1¼"	50	250	A
7612	POW	⅜" x 2¾"	1⅝"	1⅝"	50	250	A
7613	POW	⅜" x 3"	1⅝"	1⅞"	50	250	A
7614	POW	⅜" x 3½"	1⅝"	2⅜"	50	250	A
7615	POW	⅜" x 3¾"	1⅝"	2⅝"	50	250	A
7616	POW	⅜" x 5"	1⅝"	3⅞"	50	250	A
7620	POW	½" x 2¾"	2¼"	1⅜"	50	200	A
7622	POW	½" x 3¼"	2¼"	2⅜"	50	200	A
7623	POW	½" x 4½"	2¼"	3⅞"	50	200	A
7624	POW	½" x 5½"	2¼"	4⅞"	50	150	A
7626	POW	½" x 7"	2¼"	5⅝"	25	100	A
7630	POW	⅝" x 3½"	2¾"	2"	25	100	A
7632	POW	⅝" x 4½"	2¾"	3"	25	100	A
7633	POW	⅝" x 5"	2¾"	3½"	25	100	A
7634	POW	⅝" x 6"	2¾"	4½"	25	75	A
7636	POW	⅝" x 7"	2¾"	5½"	25	75	A
7638	POW	⅝" x 8½"	2¾"	7"	25	75	A
7640	POW	¾" x 4¼"	3⅞"	2⅜"	20	60	A
7641	POW	¾" x 4¾"	3⅞"	2⅞"	20	60	A
7642	POW	¾" x 5½"	3⅞"	3⅝"	20	60	A
7644	POW	¾" x 6¼"	3⅞"	4⅜"	20	60	A
7646	POW	¾" x 7"	3⅞"	5⅛"	20	60	A
7648	POW	¾" x 8½"	3⅞"	6⅝"	10	40	A

†The published length is the overall length of the anchor. Allow for fixture thickness plus one anchor diameter for the nut and washer thickness when selecting a length.

*Y = stock item; A = readily available by order

Anchors



Lok-Bolt AS™

Base Material: Concrete, Block, Brick, Stone
Size Range: ¼" x ⅝" to ¾" x 7½"
Anchor Material: Carbon Steel & Stainless Steel

The Lok-Bolt AS anchor is a preassembled single unit sleeve anchor. Extension sleeves are added to create longer lengths.

Hex Nut Lok-Bolt AS Carbon Steel

Item #	Code	Size†	Drill Dia.	Min. Embed.	Std. Box	Std. Ctn.	Stock*
5005S	POW	⅝" x 1½"	⅝"	1⅜"	100	1000	Y
5010S	POW	⅝" x 2½"	⅝"	1½"	100	500	Y
5015S	POW	⅜" x 1⅞"	⅜"	1⅝"	50	500	Y
5020S	POW	⅜" x 3"	⅜"	1⅝"	50	500	Y
5022S	POW	⅜" x 4"	⅜"	1⅝"	50	250	Y
5025S	POW	½" x 2¼"	½"	2⅛"	25	250	Y
5030S	POW	½" x 3"	½"	2¼"	25	250	Y
5034S	POW	½" x 4"	½"	2¼"	25	125	Y
5033S	POW	½" x 5¼"	½"	2¼"	25	125	Y
5032S	POW	½" x 6"	½"	2¼"	10	100	A
5035S	POW	⅝" x 2¼"	⅝"	2⅛"	25	125	Y
5038S	POW	⅝" x 3"	⅝"	2¾"	25	125	Y
5040S	POW	⅝" x 4¼"	⅝"	2¾"	10	100	Y
5045S	POW	⅝" x 6"	⅝"	2¾"	10	100	A
5050S	POW	¾" x 2½"	¾"	2⅞"	10	100	Y
5055S	POW	¾" x 4"	¾"	3⅜"	10	40	Y
5060S	POW	¾" x 5¼"	¾"	3⅜"	10	30	A
5065S	POW	¾" x 7½"	¾"	3⅜"	10	30	A



Acorn Nut Lok-Bolt AS Carbon Steel

Item #	Code	Size†	Drill Dia.	Min. Embed.	Std. Box	Std. Ctn.	Stock*
5125S	POW	¼" x ¾"	¼"	½"	100	1000	A
5150S	POW	¼" x 1⅜"	¼"	1⅞"	100	1000	Y
5175S	POW	¼" x 2¼"	¼"	1⅞"	100	1000	A

YOUR SATISFACTION
IS GUARANTEED!



Combo Flat Head Lok-Bolt AS Carbon Steel

Item #	Code	Size	Drill Dia.	Min. Embed.	Std. Box	Std. Ctn.	Stock*
5305S	POW	¼" x 1⅞"	¼"	1"	100	1000	A
5310S	POW	¼" x 2"	¼"	1⅞"	100	1000	A
5315S	POW	¼" x 3"	¼"	1⅞"	100	1000	A
5320S	POW	¼" x 4"	¼"	1⅞"	100	500	A
5325S	POW	¼" x 5¼"	¼"	1⅞"	100	500	A
5330S	POW	⅝" x 2½"	⅝"	1½"	100	1000	A
5335S	POW	⅝" x 3½"	⅝"	1½"	100	500	A
5340S	POW	⅜" x 2¾"	⅜"	1⅝"	50	500	A
5345S	POW	⅜" x 4"	⅜"	1⅝"	50	250	Y
5350S-POW	POW	⅜" x 5"	⅜"	1⅝"	50	250	Y
5360S	POW	⅜" x 6"	⅜"	1⅝"	50	250	Y



Tie-Wire Lok-Bolt AS

Item #	Code	Size	Drill Dia.	Min. Embed.	Std. Box	Std. Ctn.	Stock*
5700-POW	POW	⅝" x 1½"	⅝"	1½"	100	1000	Y

Lok-Bolt™ Extenders Carbon Steel

- For additional length



Item #	Code	Size	Drill Dia.	Std. Box	Std. Ctn.	Stock*
5684S	POW	⅜" x 1¼"	⅜"	50	500	A



Threshold Flat Head Lok-Bolt AS

Item #	Code	Size†	Drill Dia.	Min. Embed.	Std. Box	Std. Ctn.	Stock*
5500S	POW	¼" x 2"	¼"	1⅞"	100	1000	A

This size does not have a compression ring.

*Y = stock item; A = readily available by order

Anchors



SPIKE®

Base Material: Concrete, Block, Brick, Stone
Size Range: 3/16" x 1" to 1/2" x 6 1/2"
Anchor Material: Carbon Steel and Type 316 Stainless Steel

The SPIKE anchor is a patented, one-piece, tamper-proof, pre-expanded anchor. The SPIKE anchor is formed with an "S" shaped configuration at the working end of the anchor to create an expansion mechanism. Since the anchor is pre-expanded, there is no secondary tightening operation required, which greatly reduces the overall cost of an anchor installation.

Several head styles are available carbon steel or type 316 stainless steel.

Mushroom Head Grade 8.2 Carbon Steel Spike

Item #	Code	Size	Drill Dia.	Min. Embed.	Std. Box	Std. Ctn.	Stock*
5502-POW	POW	3/16" x 1"	3/16"	7/8"	100	1000	Y
5503-POW	POW	3/16" x 1 1/4"	3/16"	7/8"	100	1000	Y
5504-POW	POW	3/16" x 1 1/2"	3/16"	1 1/4"	100	1000	Y
5506	POW	3/16" x 2"	3/16"	1 1/4"	100	1000	A
5508	POW	3/16" x 2 1/2"	3/16"	1 1/4"	100	1000	A
5510-POW	POW	3/16" x 3"	3/16"	1 1/4"	100	1000	Y
5511	POW	3/16" x 3 1/2"	3/16"	1 1/4"	100	1000	Y
5512	POW	3/16" x 4"	3/16"	1 1/4"	100	500	A
5522	POW	1/4" x 1"	1/4"	7/8"	100	1000	A
5523	POW	1/4" x 1 1/4"	1/4"	1"	100	1000	A
5524-POW	POW	1/4" x 1 1/2"	1/4"	1 1/4"	100	1000	Y
5526-POW	POW	1/4" x 2"	1/4"	1 1/4"	100	1000	Y
5528-POW	POW	1/4" x 2 1/2"	1/4"	1 1/4"	100	1000	Y
5530-POW	POW	1/4" x 3"	1/4"	1 1/4"	100	1000	Y
5531	POW	1/4" x 3 1/2"	1/4"	1 1/4"	100	100	A
5532	POW	1/4" x 4"	1/4"	1 1/4"	100	500	A
5546	POW	3/8" x 2"	3/8"	1 3/4"	25	250	A
5548	POW	3/8" x 2 1/2"	3/8"	1 3/4"	25	250	A
5550	POW	3/8" x 3"	3/8"	1 3/4"	25	250	A
5551	POW	3/8" x 3 1/2"	3/8"	1 3/4"	25	250	A
5552	POW	3/8" x 4"	3/8"	1 3/4"	25	250	A
5554	POW	3/8" x 5"	3/8"	1 3/4"	25	250	A
5556	POW	3/8" x 6"	3/8"	1 3/4"	25	250	A
5569	POW	1/2" x 2 3/4"	1/2"	2 1/2"	50	200	A
5571	POW	1/2" x 3 1/2"	1/2"	2 1/2"	50	150	A
5572	POW	1/2" x 4"	1/2"	2 1/2"	25	150	A
5574	POW	1/2" x 5"	1/2"	2 1/2"	25	150	A
5577	POW	1/2" x 6 1/2"	1/2"	2 1/2"	25	150	A



Special Application SPIKE® Anchor

Tie-Wire SPIKE
Grade 8.2 Carbon Steel



- For suspended ceilings

Item #	Code	Size	Drill Dia.	Min. Embed.	Tie-Wire Hole Size	Std. Box	Std. Ctn.	Stock*
3756	POW	3/16"	3/16"	1 1/4"	3/16"	100	500	Y
3759	POW	1/4"	1/4"	1 1/4"	9/32"	100	500	Y

Pipe SPIKE Grade 8.2
Carbon Steel



- For rod hanging

Item #	Code	Head Size	Drill Dia.	Min. Embed.	Std. Box	Std. Ctn.	Stock*
3755	POW	1/4"	3/16"	1 1/4"	100	1000	Y
3758	POW	3/8"	1/4"	1 3/4"	50	500	Y



Zamac Hammer-Screw®

Base Material: Concrete, Block, Brick, Stone
Size Range: 1/4" x 3/4" to 1/4" x 3"
Anchor Material: Zamac Alloy w/Carbon Steel Drive Screw or Perma-Seal Coated Drive Screw

Developed as an improvement over Nailin anchors, the Zamac Hammer-Screw is a unique, one-step drive anchor featuring a Phillips-type head and an internal screw thread that allows the anchor to be removed.

Zamac Hammer-Screw Mushroom Head
w/#2 Phillips-Type Screw - Carbon Steel

Item #	Code	Size	Drill Dia.	Std. Box	Std. Ctn.	Stock*
2839	POW	1/4" x 3/4"	1/4"	100	500	Y
2840	POW	1/4" x 1"	1/4"	100	500	A
2842	POW	1/4" x 1 1/4"	1/4"	100	500	Y
2844	POW	1/4" x 1 1/2"	1/4"	100	500	A
2846	POW	1/4" x 2"	1/4"	100	500	Y
2848	POW	1/4" x 2 1/4"	1/4"	100	500	Y
2850	POW	1/4" x 3"	1/4"	100	500	Y

*Y = stock item; A = readily available by order

Anchors



Zamac Nailin®

Base Material: Concrete, Block, Brick, Stone
Size Range: 3/16" x 7/8" to 1/4" x 3"
Anchor Material: Zamac Alloy w/Carbon or Stainless Steel Drive Pin

The Zamac Nailin is a tamper-proof, drive pin type anchor.

Mushroom Head Zamac Nailin w/Carbon Steel Nail

Item #	Code	Size	Drill Dia.	Std. Box	Std. Ctn.	Stock*
2802-POW	POW	3/16" x 7/8"	3/16"	100	500	Y
2806	POW	1/4" x 3/4"	1/4"	100	500	A
2808	POW	1/4" x 1"	1/4"	100	500	Y
2814	POW	1/4" x 1 1/4"	1/4"	100	500	A
2820-POW	POW	1/4" x 1 1/2"	1/4"	100	500	Y
2826	POW	1/4" x 2"	1/4"	100	500	Y
2804	POW	1/4" x 3"	1/4"	100	500	A

Mushroom Head Zamac Nailin w/Type 304 Stainless Steel Nail

Item #	Code	Size	Drill Dia.	Std. Box	Std. Ctn.	Stock*
2858	POW	1/4" x 1"	1/4"	100	500	A
2864	POW	1/4" x 1 1/4"	1/4"	100	500	A
2870	POW	1/4" x 1 1/2"	1/4"	100	500	Y
2876	POW	1/4" x 2"	1/4"	100	500	A



Nylon Nailin®

Base Material: Concrete, Block, Brick, Stone
Size Range: 3/16" x 1" to 1/4" x 6"
Anchor Material: Engineered Nylon w/Carbon or Stainless Steel Drive Pin

The Nylon Nailin is a plastic drive pin type anchor.

Mushroom Head Nylon Nailin w/Carbon Steel Nail

Item #	Code	Size	Drill Dia.	Std. Box	Std. Ctn.	Stock*
2433	POW	3/16" x 1"	3/16"	100	1000	A
2513	POW	1/4" x 3/4"	1/4"	100	1000	A
2523	POW	1/4" x 1"	1/4"	100	1000	Y
2543	POW	1/4" x 1 1/2"	1/4"	100	1000	Y
2563	POW	1/4" x 2"	1/4"	100	1000	Y
2573	POW	1/4" x 3"	1/4"	100	1000	Y
2583	POW	1/4" x 4"	1/4"	100	1000	A
2593	POW	1/4" x 6"	1/4"	100	1000	Y

*Y = stock item; A = readily available by order



DCK290L2

See our complete line of DeWALT drills on pages 4-10



BOSCH



CLPK221-181

See our complete line of Bosch drills on pages 13-20



2697-22

See our complete line of Milwaukee drills on pages 23-39

Anchors

TAPPER+™

Base Material: Uncracked Concrete, Block, Brick, Wood, Pressure Treated Lumber
Size Range: 3/16" x 1 1/4" to 1/4" x 6"
Anchor Material: Carbon Steel, Type 304 & Type 410 Stainless Steel

The Tapper+ is a one-piece, self-tapping concrete screw for use in a variety of light to medium duty applications in base materials. It features a corrosion resistant Perma-Seal® coating and an optimized thread design for lower torque. The screw also incorporates a gimlet thread point for wood based materials (no predrilling required).

CODE LISTED
ICC-ES ESR-3068

TESTED TO
ICC-ES AC106
MASONRY

TESTED TO
ICC-ES AC233
WOOD

TESTED TO
ICC-ES AC193
PRESSURE
TREATED LUMBER

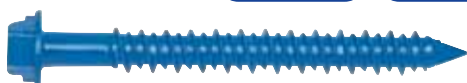

Blue Perma-Seal™ TAPPER+ Hex Head

Item #	Code	Size	Drill Ref. Straight / SDS Hex	Std. Box	Stock*
2700SD	TAP	3/16" x 1 1/4"	2781 / 2793	100	Y
2702SD	TAP	3/16" x 1 3/4"	2781 / 2793	100	Y
2704SD	TAP	3/16" x 2 1/4"	2782 / 2793	100	Y
2706SD	TAP	3/16" x 2 3/4"	2782 / 2793	100	Y
2708SD	TAP	3/16" x 3 1/4"	2783 / 2794	100	Y
2710SD	TAP	3/16" x 3 3/4"	2783 / 2794	100	Y
2712SD	TAP	3/16" x 4"	2783 / 2794	100	A
2720SD	TAP	1/4" x 1 1/4"	2785 / 2796	100	Y
2722SD	TAP	1/4" x 1 3/4"	2785 / 2796	100	Y
2724SD	TAP	1/4" x 2 1/4"	2786 / 2796	100	Y
2726SD	TAP	1/4" x 2 3/4"	2786 / 2796	100	Y
2728SD	TAP	1/4" x 3 1/4"	2787 / 2797	100	Y
2730SD	TAP	1/4" x 3 3/4"	2787 / 2797	100	Y
2732SD	TAP	1/4" x 4"	2787 / 2797	100	Y

Blue Perma-Seal™ TAPPER+ Phillips Flat Head

Item #	Code	Size (Inches)	Drill Ref. Straight / SDS Hex	Std. Box	Stock*
2740SD	TAP	3/16" x 1 1/4"	2781 / 2793	100	Y
2742SD	TAP	3/16" x 1 3/4"	2781 / 2793	100	Y
2744SD	TAP	3/16" x 2 1/4"	2782 / 2793	100	Y
2746SD	TAP	3/16" x 2 3/4"	2782 / 2793	100	Y
2748SD	TAP	3/16" x 3 1/4"	2783 / 2794	100	Y
2750SD	TAP	3/16" x 3 3/4"	2783 / 2794	100	A
2752SD	TAP	3/16" x 4"	2783 / 2794	100	Y
2760SD	TAP	1/4" x 1 1/4"	2785 / 2796	100	Y
2762SD	TAP	1/4" x 1 3/4"	2785 / 2796	100	Y
2764SD	TAP	1/4" x 2 1/4"	2786 / 2796	100	Y
2766SD	TAP	1/4" x 2 3/4"	2786 / 2796	100	Y
2768SD	TAP	1/4" x 3 1/4"	2787 / 2797	100	Y
2770SD	TAP	1/4" x 3 3/4"	2787 / 2797	100	Y
2772SD	TAP	1/4" x 4"	2787 / 2797	100	Y
2774SD	TAP	1/4" x 5"	2788 / 2797	100	Y
2776SD	TAP	1/4" x 6"	2789 / 2797	100	Y

Utica 315-724-7119

Watertown 315-788-2612

Syracuse 315-671-4400



TAPPER™

Base Material: Concrete, Block, Brick
Size Range: 3/16" x 1 1/4" to 3/8" x 6"
Anchor Material: Carbon Steel, Type 304 & Type 410 Stainless Steel

The Tapper concrete screw is designed to meet the needs of most light to medium duty applications in concrete, block and brick. The TAPPER concrete screw anchor is produced in either hex washer head or Phillips flat head styles from Perma-Seal coated or zinc plated carbon steel and type 304 stainless steel. For heavy-duty applications, the 3/8" size is made in zinc plated carbon steel.



Zinc Plated Carbon Steel TAPPER Hex Head

Item #	Code	Size	Drill Ref. Straight / SDS Hex	Std. Box	Stock*
H38X2	TAP	3/8" x 2"	5860 / 5866	100	Y
H38X3	TAP	3/8" x 3"	5860 / 5866	100	Y
H38X4	TAP	3/8" x 4"	5862 / 5868	100	A



Zinc Plated Carbon Steel TAPPER Phillips Flat Head

Item #	Code	Size	Drill Ref. Straight / SDS Hex	Std. Box	Stock*
P38X3	TAP	3/8" x 3"	5860 / 5866	100	Y
P38X4	TAP	3/8" x 4"	5861 / 5868	100	Y
P38X5	TAP	3/8" x 5"	5862 / 5868	100	Y
P38X6	TAP	3/8" x 6"	5863 / 5868	100	Y

Drill Bit for Perma-Seal TAPPER+™



Item #	Code	Size	Usable Length	Stock*
532X312BIT	POW	5/32" x 3 1/2"	2"	Y
532X412BIT	POW	5/32" x 4 1/2"	3"	Y
532X512BIT	POW	5/32" x 5 1/2"	4"	Y
316X312BIT	POW	3/16" x 3 1/2"	2"	Y
316X412BIT	POW	3/16" x 4 1/2"	3"	Y
316X512BIT	POW	3/16" x 5 1/2"	4"	Y
316X612BIT	POW	3/16" x 6 1/2"	5"	Y
316X712BIT	POW	3/16" x 7 1/2"	6"	Y

Carbide Drill Bit for Tapper™



Item #	Code	Size	Usable Length	Stock*
2793	POW	5/32" x 5"	3"	Y
2794	POW	5/32" x 7"	5"	A
2796	POW	3/16" x 5"	3"	Y
2797	POW	3/16" x 7"	5"	Y
5866	POW	1/4" x 6"	4"	Y

Anchors



perma-grip®

Perma-grip® (Gripcon) Concrete Fastening System

The Perma-grip system consists of the Perma-grip corrosion-resistant fasteners and special close tolerance drill bits to assure positive engagement. Perma-grip fasteners are mechanically galvanized and designed to penetrate the predrilled hole with minimum effort. The $\frac{3}{8}$ " carbide tipped drill bits are offered for hammer drills and rotary hammers.**

Features

- No special driving tools required
- No head shearing
- Control of embedment
- Compatible with steel and plastic stress plates

**One Perma-grip $\frac{3}{16}$ " drill bit is included in each box off 100 anchors. Rotary hammer Perma-grip close tolerance drill bits (sold separately) are recommended for higher strength concrete.

Item #	Code	Size	Straight Shank Bit	SDS Bit UL - OAL	Box Qty.	Stock*
GRI118	GRI	1 1/8"	4 1/2"	2" - 4"	100	Y
GRI112	GRI	1 1/2"	4 1/2"	2" - 4"	100	Y
GRI2	GRI	2"	4 1/2"	4" - 6"	100	Y
GRI212	GRI	2 1/2"	4 1/2"	4" - 6"	100	Y
GRI3	GRI	3"	5 1/2"	4" - 6"	100	Y
GRI312	GRI	3 1/2"	5 1/2"	4" - 6"	100	Y
GRI4	GRI	4"	6 1/2"	6" - 8"	100	Y
GRI412	GRI	4 1/2"	6 1/2"	6" - 8"	100	Y
GRI4BIT	GRI	4"	Perma-grip drill bit		1	A
GRI5	GRI	5"	7 1/2"	6" - 8"	100	Y
GRI512	GRI	5 1/2"	7 1/2"	6" - 8"	100	A
GRI5BIT	GRI	5"	Perma-grip drill bit		1	A
GRI6	GRI	6"	7 1/2"	8" - 10"	100	A
GRI612	GRI	6 1/2"	8 3/4"	8" - 10"	100	A
GRI6BIT	GRI	6"	Perma-grip drill bit		1	A
GRI7	GRI	7"	8 3/4"	8" - 10"	100	A
GRI712BIT	GRI	7 1/2"	Perma-grip drill bit		1	A
GRI812BIT	GRI	8 1/2"	Perma-grip drill bit		1	A

Threaded Rod

- Carbon steel with zinc finish
- USS national Coarse
- 6' pieces

Item #	Code	Size	Stock*
ROD14X6	ROD	1/4-20	Y
ROD516X6	ROD	5/16-18	A
ROD38X6	ROD	3/8-16	Y
ROD12X6	ROD	1/2-13	Y
ROD58X6	ROD	5/8-11	Y
ROD34X6	ROD	3/4-10	Y
ROD1X6	ROD	1-8	Y

Anchor Bolt w/Nut & Washer

Anchor bolts are available plain finish, hot dipped galvanized (HDG), zinc and stainless available upon request.

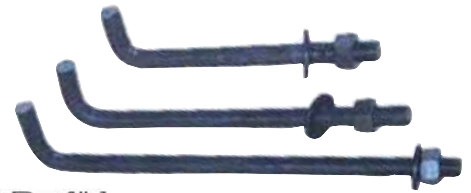
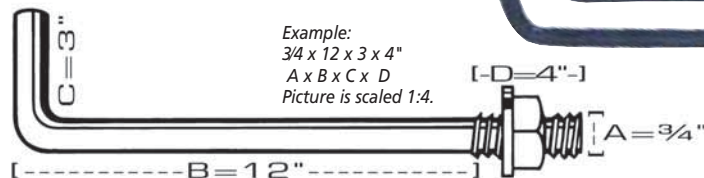

Item #	Code	Size	Stock*
—	AB	3/4 x 12 x 3 x 4	A
—	AB	3/4 x 18 x 3 x 4	A
—	AB	3/4 x 24 x 3 x 4	A
—	AB	3/4 x 30 x 3 x 4	A
—	AB	3/4 x 12 x 3 x 4	A
—	AB	3/4 x 18 x 3 x 4	A
—	AB	1 x 15 x 3 x 4	A
—	AB	1 x 24 x 3 x 6	A
—	AB	1 x 15 x 3 x 6	A
—	AB	1 x 18 x 3 x 6	A
—	AB	1 x 30 x 3 x 6	A
—	AB	1 x 36 x 3 x 6	A
—	AB	3/8 x 6 x 1 x 1 1/2	A
—	AB	3/8 x 8 x 1 x 1 1/2	A
—	AB	3/8 x 10 x 1 x 1 1/2	A
—	AB	3/8 x 12 x 1 x 1 1/2	A

Item #	Code	Size	Finish	Stock*
AB12X6	AB	1/2 x 6 x 1 x 1 7/8	Plain	Y
AB12X8	AB	1/2 x 8 x 1 x 1 7/8	Plain	Y
AB12X10	AB	1/2 x 10 x 1 x 1 7/8	Plain	Y
AB12X12	AB	1/2 x 12 x 1 x 1 7/8	Plain	Y
—	AB	1/2 x 14 x 1 x 1 7/8	AB	A
—	AB	1/2 x 16 x 1 x 1 7/8	AB	A
—	AB	1/2 x 18 x 1 x 1 7/8	AB	A
—	AB	5/8 x 6 x 2 x 4	AB	A
—	AB	5/8 x 8 x 2 x 4	AB	A
—	AB	5/8 x 10 x 2 x 4	AB	A
—	AB	5/8 x 12 x 2 x 4	AB	A
—	AB	5/8 x 14 x 2 x 4	AB	A
—	AB	5/8 x 16 x 2 x 4	AB	A
—	AB	5/8 x 18 x 2 x 4	AB	A
ABHDG12X6	AB	1/2 x 6 x 1 x 1 7/8	HDG	Y
ABHDG12X8	AB	1/2 x 8 x 1 x 1 7/8	HDG	Y

*Y = stock item; A = readily available by order

Anchors



CODE LISTED
ICC-ES ESR-2526

CODE LISTED
ICC-ES ESR-1678

Wedge-Bolt®+

Base Material: Normal-weight Concrete, Structural Sand-Lightweight Concrete, Concrete over Metal Deck, Grouted CMU

Size Range: ¼" diameter (uncracked concrete), ⅜" diameter through ¾" diameter (cracked and uncracked concrete, grouted CMU)

Anchor Material: Zinc-plated carbon steel body and hex head

The Wedge-Bolt® is a one-piece, heavy-duty screw anchor with a finished hex head. It is simple to install, easy to identify and fully removable.

Wedge-Bolt+ is marked with a blue tip and must be installed with a matched tolerance Wedge-Bit.

Carbon Steel Hex Head Wedge-Bolt

Item #	Code	Size†	Min. Embed.	Thread Length	Std. Box	Std. Ctn.	Stock*
7204SD	POW	¼" x 1¼"	1"	1½"	100	500	Y
7206SD	POW	¼" x 1¾"	1"	1½"	100	500	Y
7208SD	POW	¼" x 2¼"	1"	2"	100	500	Y
7210SD	POW	¼" x 3"	1"	2¾"	100	500	Y
7220SD	POW	⅜" x 1¾"	1½"	1½"	50	250	A
7222SD	POW	⅜" x 2½"	1½"	2¼"	50	250	Y
7224SD	POW	⅜" x 3"	1½"	2¾"	50	250	Y
7226SD	POW	⅜" x 4"	1½"	3¾"	50	250	Y
7240SD	POW	½" x 2"	1¾"	1¾"	50	200	Y
7242SD	POW	½" x 2½"	1¾"	2¼"	50	200	Y
7244SD	POW	½" x 3"	1¾"	2¾"	50	150	Y
7246SD	POW	½" x 4"	1¾"	3¾"	50	150	Y
7248SD	POW	½" x 5"	1¾"	3¾"	25	100	Y
7250SD	POW	½" x 6"	1¾"	3¾"	25	75	Y
7260SD	POW	⅝" x 3"	2½"	2¾"	25	100	A
7262SD	POW	⅝" x 4"	2½"	3¾"	25	100	Y
7264SD	POW	⅝" x 5"	2½"	3¾"	25	75	A
7266SD	POW	⅝" x 6"	2½"	3¾"	25	75	Y
7280SD	POW	¾" x 3"	2½"	2¾"	20	60	Y
7282SD	POW	¾" x 4"	2½"	3¾"	20	60	A
7284SD	POW	¾" x 5"	2½"	3¾"	20	60	A
7286SD	POW	¾" x 6"	2½"	3¾"	20	60	Y
7288SD	POW	¾" x 8"	2½"	3¾"	10	40	A

*Published length is measured from below the hex washer head to the end of the anchor.

Straight Shank Wedge-Bit

Item #	Code	Size	Usable Length	Stock*
WB1372	POW	¼" x 6"	4"	Y
WB1380	POW	⅜" x 6"	4"	Y
WB1390	POW	½" x 5"	4"	Y
WB1394	POW	½" x 13"	11"	Y

SDS-Max Wedge-Bit

Item #	Code	Size	Usable Length	Stock*
1354	POW	½"	8"	A
1356	POW	⅝"	8"	A
1358	POW	¾"	8"	A

Spline Wedge-Bit

Item #	Code	Size	Usable Length	Stock*
WB1340	POW	½" x 13"	8"	Y
WB1344	POW	⅝" x 13"	8"	Y

Installation Procedure for Powers Wedge-Bolts®

#1 Determine anchor & embedment length.

Anchor length = distance from below hex washer head to end of anchor.

Embedment length = embedment depth + thickness of fixture.

#2 Using the proper diameter Wedge-Bit, drill a hole into the base material to a depth of at least ½" or one anchor diameter deeper than the embedment required. Be sure to use a Wedge-Bit. Blow the hole clean of dust and other material. [When attaching to hollow base material, insert the appropriate Block Plug into the anchor hole.]

#3 Insert the anchor through the fixture into the anchor hole. Begin tightening the anchor by rotating clockwise and applying pressure in toward the base material. This will engage the first few threads as the anchor begins to advance.

#4 Continue tightening the anchor until the head is firmly seated against the fixture while achieving the required embedment depth. In extremely dense materials, use of an impact wrench is recommended.

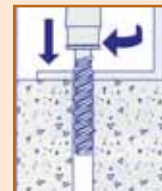

Wedge-Bit™ Carbide Drill Bit

For proper performance, Wedge-Bolt® anchors must be installed with a Wedge-Bit. The Wedge-Bit has a special matched tolerance range designed to provide optimum performance for the anchor.

SDS-Plus® Wedge-Bit

Item #	Code	Size	Usable Length	Stock*
WB1314	POW	¼" x 6"	4"	Y
WB1316	POW	⅜" x 6"	4"	Y
WB1318	POW	⅜" x 8"	6"	Y
WB1320	POW	½" x 6"	4"	Y
WB1322	POW	½" x 10"	8"	Y
WB1334	POW	½" x 12"	10"	Y
WB1324	POW	⅝" x 8"	6"	Y
WB1328	POW	¾" x 8"	6"	Y
WB1330	POW	¾" x 12"	10"	Y



Anchors

Steel Dropin

Base Material: Solid Concrete, Solid Block, Hard Stone
Size Range: ¼" to ¾" Standard Thread, ½" & ¾" Coil Thread
Anchor Material: Carbon Steel and Type 303 Stainless Steel

The Steel Dropin is an all-steel, machine bolt anchor with standard thread or coil thread for forming applications.

Carbon Steel Dropin (Smooth Wall)

Item #	Code	Size	Drill Dia.	Min. Depth	Thread Depth	Std. Box	Stock*
6304	POW	¼"	⅜"	1"	⅞"	100	Y
6306	POW	⅜"	½"	1⅞"	⅝"	50	Y
6308	POW	½"	⅝"	2"	1⅜"	50	Y
6320	POW	⅝"	⅞"	2½"	1⅜"	25	Y
6312	POW	¾"	1"	3⅜"	1⅜"	10	Y

Type 303 Stainless Steel Dropin

Item #	Code	Size	Drill Dia.	Min. Depth	Thread Depth	Std. Box	Stock*
6204	POW	¼"	⅜"	1"	⅞"	100	A
6206	POW	⅜"	½"	1⅞"	⅝"	50	A
6208	POW	½"	⅝"	2"	1⅜"	50	A
6210	POW	⅝"	⅞"	2½"	1⅜"	25	A
6212	POW	¾"	1"	3⅜"	1⅜"	10	A

Hollow-Set Dropin™

Base Material: Concrete, Block, Brick, Stone, Precast Hollow Core Plank
Size Range: ¼" to ⅝"
Anchor Material: Zamac Alloy w/Carbon Steel or Stainless Steel Cones

The Hollow-Set Dropin is an internally threaded expansion anchor. It is designed for anchoring in hollow base materials, such as hollow concrete blocks and brick with weep holes, and in solid base materials. The Hollow-Set Dropin overcomes the problem of spalling on the back side of the wall, which often decreases the wall thickness available for anchoring to 1" or less.

Zamac Dropin with Carbon Steel Cone

Item #	Code	Size	Drill Dia.	Overall Length	Sleeve Length	Std. Box	Std. Ctn.	Stock*
9320-POW	POW	¼"	⅜"	⅞"	⅝"	100	1,000	Y
9330	POW	⅝"	⅝"	1⅝"	1⅝"	50	500	A
9340	POW	⅜"	⅝"	1⅝"	1⅝"	50	500	Y
9350	POW	½"	¾"	1¾"	1¼"	50	250	Y
9360	POW	⅝"	1"	2"	1½"	25	125	A



Carbon Steel Coil Thread Dropin**

Item #	Code	Size	Drill Dia.	Min. Depth	Thread Depth	Std. Box	Stock*
6330	POW	½"	⅝"	2"	1⅜"	50	Y
6332	POW	¾"	1"	3⅜"	1⅜"	10	A

**Use Setting Tool item no. 6309 for ½" size, item no. 6313 for ¾" size.

Setting Tool for Steel Dropin Anchor

Item #	Code	Size	Std. Box	Stock*
6305	POW	¼"	10	Y
6307	POW	⅜"	10	Y
6309	POW	½"	10	Y
6311	POW	⅝"	5	Y
6313	POW	¾"	5	A



Setting Tool for Hollow-Set Dropin

For Solid Base Materials



For Hollow Base Materials



Item #	Code	Size	Stock*
9322	POW	¼"	A
9342	POW	⅝" & ⅜"	A
9352	POW	½"	A
9362	POW	⅝"	A

Item #	Code	Size	Stock*
9323	POW	¼"	A
9333	POW	⅝"	A
9343	POW	⅜"	A
9353	POW	½"	A
9363	POW	⅝"	A

**Need help with specifications?
Call us—we can help!**

*Y = stock item; A = readily available by order

Anchors

Calk-In™ Machine Screw Anchor

Base Material: Concrete, Block, Brick
Size Range: 8-32 to 3/4"-10
Anchor Material: Zamac Alloy and Lead

The Calk-In is a preassembled, precision cast, calking-type machine bolt anchor that consists of an antimonial lead alloy calking sleeve and a Zamac alloy internally-threaded expander cone.



Calk-In Anchor



Setting Tool for Calk-In Anchor

Item #	Code	Size	Drill Dia.	Min. Depth	Std. Box	Std. Ctn.	Stock*
9205	POW	8-32	1/4"	1/2"	100	1,000	A
9210	POW	10-24	3/8"	5/8"	100	1,000	A
9220	POW	1/4"-20	1/2"	7/8"	100	1,000	A
9225	POW	3/16"-18	5/8"	1"	50	250	A
9230	POW	3/8"-16	3/4"	1 1/4"	50	250	A
9240	POW	1/2"-13	7/8"	1 1/2"	50	250	A
9245	POW	5/8"-11	1 1/8"	2"	50	50	A
9250	POW	3/4"-10	1 1/4"	2 1/4"	50	50	A

Item #	Code	Size	Stock*
9201	POW	8	A
9211	POW	10	A
9221	POW	1/4"	A
9226	POW	5/16"	A
9231	POW	3/8"	A
9241	POW	1/2"	A
9246	POW	5/8"	A
9251	POW	3/4"	A

Single Expansion Anchor

Base Material: Concrete
Size Range: 1/4" to 5/8"
Anchor Material: Zamac Alloy



The Single is a machine bolt anchor consisting of a preassembled set of expansion shields and an expander cone formed from Zamac alloy. The Single is designed for use in concrete, and may be suitable for use in block, brick and stone base materials.

Item #	Code	Size	Anchor Length	Drill Dia.	Min. Hole Depth	Std. Box	Std. Ctn.	Stock*
9650	POW	1/4"	1 1/4"	1/2"	1 3/8"	50	250	A
9655	POW	5/16"	1 1/2"	5/8"	1 5/8"	50	250	A
9665	POW	3/8"	1 1/2"	5/8"	1 5/8"	50	250	Y
9675	POW	1/2"	2 1/16"	7/8"	2 1/2"	25	125	A
9685	POW	5/8"	2 5/8"	1"	2 3/4"	25	125	A

Double Expansion Anchor

Base Material: Concrete, Block, Brick, Stone
Size Range: 1/4" to 3/4"
Anchor Material: Zamac Alloy



The Double is a dual expansion machine bolt anchor particularly suited for materials of questionable strength. It can be used in solid concrete and some block, brick and stone base materials.

Item #	Code	Size	Anchor Length	Drill Dia.	Min. Hole Depth	Std. Box	Std. Ctn.	Stock*
9510	POW	1/4"	1 3/8"	1/2"	1 1/4"	50	250	A
9515	POW	5/16"	1 5/8"	5/8"	1 1/2"	50	250	A
9520	POW	3/8"	2"	3/4"	1 3/4"	50	250	Y
9525	POW	1/2"	2 1/2"	7/8"	2 1/4"	25	125	Y
9530	POW	5/8"	2 3/4"	1"	2 1/2"	25	125	A
9535	POW	3/4"	3 1/16"	1 1/4"	3 1/2"	10	100	A

Bantam Plug

Base Material: Concrete, Block, Brick, Wallboard
Size Range: 6-8 x 3/4" to 14-16 x 1 1/2"
Anchor Material: Plastic

The Bantam Plug is a plastic anchor designed for use in lightweight fixtures with a sheet metal or wood screw. The anchor is recommended for light duty static applications where holding power is not a critical factor. It should not be used overhead.

Item #	Code	Size	Drill Dia.	Min. Depth	Std. Box	Std. Ctn.	Stock*
7559	POW	6-8 x 3/4"	3/16"	3/4"	100	1,000	A
7569	POW	8-10 x 7/8"	3/16"	7/8"	100	1,000	Y
7579	POW	10-12 x 1"	1/4"	1"	100	1,000	Y
7589	POW	14-16 x 1 1/2"	5/16"	1 1/2"	50	500	Y



Bantam Plug Kit

Includes:

- (100) Bantam Anchors
- (100) Slotted/Phillips Pan Head Sheet Metal Screws
- (1) Drill Bit

Item #	Code	Kit #	Anchor Size	Screw Size	Min. Depth	Std. Ctn.	Stock*
8934-POW	POW	B-8	8-10	8 x 1"	7/8"	10	Y
8936	POW	B-10	10-12	10 x 1"	1"	10	Y
8938	POW	B-12	10-12	12 x 1"	1"	10	Y

*Y = stock item; A = readily available by order

Anchors

Vertigo™ Rod Hanger System

Base Material: Steel, Wood, Concrete
Size Range: 1/4" to 1/2"
Anchor Material: Carbon Steel

Vertigo is an all steel threaded fastening system for suspending steel threaded rod and other assemblies. Vertigo can be installed in a variety of base materials including steel bar joists and beams, wood frame columns and beams, as well as concrete ceilings, beams and columns. In wood and steel base materials, Vertigo is also offered in a side mount style for lateral installation of 1/4" and 3/8" diameter steel threaded rods onto joists, columns and trusses. For all steel and wood Vertigo fasteners, a red Vertigo Socket Driver is recommended to provide proper installation with a screw gun or hammer drill in "rotation only" mode. Concrete Vertigo fasteners should be installed with the appropriate size standard drive sockets and hammer drill or powered impact wrench.



Steel Vertical Hanger



Item #	Code	Rod Size	Screw Shank Size & Length	Point Style	Std. Box	Std. Ctn.	Stock*
#3 FOR PURLINS							
7155	POW	1/4"	1/4"-20 x 1"	#3	100	500	Y
7157	POW	3/8"	1/4"-20 x 2"	#3	100	500	A
7158	POW	3/8"	1/4"-20 x 1" (w/nuts)	#3	100	500	A
7159	POW	3/8"	1/4"-20 x 1 1/2"	#3	100	500	Y
7160	POW	3/8"	1/4"-20 x 1 1/2" (w/nuts)	#3	100	500	A
#5 FOR BEAMS							
7152	POW	1/4"	12-24 x 1 1/2"	#5	100	500	A
7154	POW	3/8"	12-24 x 1 1/2" (w/nuts)	#5	100	500	A
7161	POW	1/2"	12-24 x 1 1/2" (w/nuts)	#5	100	500	A

Steel Side Hanger



Item #	Code	Rod Size	Screw Shank Size & Length	Point Style	Std. Box	Std. Ctn.	Stock*
#3 FOR PURLINS							
7183	POW	1/4"	1/4"-20 x 1"	#3	100	500	A
7184	POW	3/8"	1/4"-20 x 1" (w/nuts)	#3	100	500	A
7186	POW	3/8"	1/4"-20 x 1 1/2" (w/nuts)	#3	100	500	Y
7188	POW	3/8"	1/4"-20 x 2" (w/nuts)	#3	100	500	A
#5 FOR BEAMS							
7200	POW	1/4"	12-24 x 1 1/2"	#5	100	500	A
7201	POW	3/8"	12-24 x 1 1/2" (w/nuts)	#5	100	500	A

Concrete Vertical Hanger



Item #	Code	Rod Size	Screw Shank Size & Length	Point Style	Std. Box	Std. Ctn.	Stock*
7171	POW	1/4"	1/4" x 1 1/4"	ANSI WB thread	100	500	Y
7173	POW	3/8"	1/4" x 1 1/2"	ANSI WB thread	100	500	A
7175	POW	1/2"	3/8" x 2 3/4"	ANSI WB thread	50	250	A

Wood Vertical Hanger



Item #	Code	Rod Size	Screw Shank Size & Length	Point Style	Std. Box	Std. Ctn.	Stock*
7163	POW	1/4"	1/4" x 2"	TYPE 17	100	500	Y
7203	POW	3/8"	1/4" x 1"	TYPE 17	100	500	A
7165	POW	3/8"	1/4" x 2"	TYPE 17	100	500	A
7167	POW	3/8"	1/4" x 3"	TYPE 17	100	500	Y
7169	POW	3/8"	1/4" x 4"	TYPE 17	100	500	A
7162	POW	3/8"	3/8" x 2 1/2"	TYPE 17	100	500	A
7164	POW	1/2"	3/8" x 2 1/2"	TYPE 17	100	500	A

Vertigo Accessories

Driver Socket						
Item #	Code	Description	Color	Box	Carton	Stock*
7187	POW	Universal Steel & Wood Socket	RED	5	25	Y
7195	POW	1/4" Concrete Socket	BLUE	5	25	A
7197	POW	3/8" Concrete Socket	BLUE	5	25	Y
7198	POW	1/2" Concrete Socket	BLUE	5	25	A
Pole Tool						
7166	POW	6'-12' Pole Tool (includes three Jaw Chuck)	—	1	1	A

Don't have the right drive socket size?
See pages 92-93 for any size socket.

*Y = stock item; A = readily available by order

Anchors

Wall-Dog® Light-Duty Anchor

Base Material: Wallboard (1/2", 5/8" & double wallboard), Plywood, Concrete, Block (hollow or grout filled), Brick, Wood, Plaster, Masonry
Size Range: 3/16" dia. x 2 1/2" length max.
Anchor Material: Case Hardened Carbon Steel

The Wall-Dog is an all steel, one-piece screw anchor that features high-profile threads for easy fastening into wallboard and other masonry base materials. The deep cutting, corkscrew-like threads provide for smooth entry and a powerful hold. When removed, the Wall-Dog leaves a much smaller hole than toggles and other systems. No predrilling is required for fastening into wallboard or wood. Fastening into concrete, hollow or grout-filled block, brick and plaster requires a predrilled 3/16" ANSI hole.

Wall-Dog Phillips Oval Head

Item #	Code	Size	Finish	Std. Box	Std. Ctn.	Stock*
WD2314	POW	1 1/4"	Zinc	100	1,000	Y

Wall-Dog Phillips Pan Head

Item #	Code	Size	Finish	Std. Box	Std. Ctn.	Stock*
WD2316	POW	1 1/4"	Zinc	100	1,000	Y
WD2330	POW	1 1/4"	White	100	1,000	Y



Zip-It®

Base Material: Wallboard
Size Range: Use with No. 6 or No. 8 Screw
Anchor Material: Engineered Nylon or Zamac Alloy

The Zip-It anchor is a one piece, self-drilling anchor designed for use in hollow gypsum wallboard for light-duty loads.

Nylon Zip-It

Item #	Code	Description	Wall Thickness	Std. Box	Stock*
2345	POW	Std. box, no screws	3/8" to 1"	100	Y
2348	POW	Std. box, No. 8 x 1" screws	3/8" to 1"	100	Y

Zinc Zip-It

Item #	Code	Description	Wall Thickness	Std. Box	Stock*
2346	POW	Std. box, no screws	3/8" to 1"	100	Y
2349	POW	Std. box, No. 8 x 1" screws	3/8" to 1"	100	A

Zip-It & Zip-It Jr. Kits

Item #	Code	Material	Description	Stock*
2368	POW	Nylon	(50) anchors & No. 8 x 1" screws, (1) No. 2 power bit	Y
2369	POW	Zinc	(50) anchors & No. 8 x 1" screws, (1) No. 2 power bit	Y
2367	POW	Nylon	(50) anchors & No. 6 x 1" screws, (1) No. 2 power bit	A

Toggle Bolt

Base Material: Hollow Block, Wallboard, Plaster
Size Range: 1/8" x 2" to 1/2" x 4"
Anchor Material: Carbon Steel

The Toggle Bolt is a two-part assembly consisting of a spring wing toggle and a machine screw.

Combo Round Head

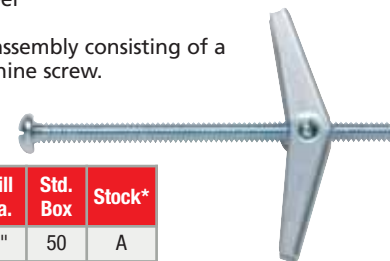

Item #	Code	Size	Drill Dia.	Std. Box	Stock*
4021	POW	1/8" x 2"	3/8"	50	A
4031	POW	1/8" x 3"	3/8"	50	Y
4041	POW	1/8" x 4"	3/8"	50	A
4121	POW	3/16" x 2"	1/2"	50	A
4131	POW	3/16" x 3"	1/2"	50	Y
4141-POW	POW	3/16" x 4"	1/2"	50	Y
4151	POW	3/16" x 5"	1/2"	50	A
4161	POW	3/16" x 6"	1/2"	50	A
4231	POW	1/4" x 3"	5/8"	50	Y
4241	POW	1/4" x 4"	5/8"	50	Y
4251	POW	1/4" x 5"	5/8"	50	A
4261	POW	1/4" x 6"	5/8"	50	Y
4331	POW	5/16" x 3"	7/8"	25	A
4341	POW	5/16" x 4"	7/8"	25	A
4351	POW	5/16" x 5"	7/8"	25	A
4361	POW	5/16" x 6"	7/8"	25	A
4431	POW	3/8" x 3"	7/8"	25	A
4441	POW	3/8" x 4"	7/8"	25	Y
4451	POW	3/8" x 5"	7/8"	25	A
4461	POW	3/8" x 6"	7/8"	25	A
4541	POW	1/2" x 4"	1 1/4"	25	A

Toggle Wing Only



Item #	Code	Size	Drill Dia.	Std. Box	Stock*
4000	POW	1/8"	3/8"	100	A
4020	POW	3/16"	1/2"	100	A
4220-POW	POW	1/4"	5/8"	100	Y
4330	POW	5/16"	7/8"	50	A
4430	POW	3/8"	7/8"	50	Y
4540	POW	1/2"	1 1/4"	25	A

*Y = stock item; A = readily available by order

Anchors

LEGS Wallboard Anchor

Base Material: Wallboard
Size Range: Use with No. 6 or No. 8 Screw
Anchor Material: Carbon Steel



The LEGS anchor is a fast, easy to use expansion anchor with a pierce point; no predrilling is required. Removal of the anchor is easy and, once removed, only a small slit in the wallboard remains.

Item #	Code	Description	Std. Box	Std. Ctn.	Stock*
2336	POW	LEGS Wallboard Anchor	100	1,000	A
2335	POW	LEGS Anchor w/No. 8 x 1" Screw	100	1,000	A
2338	POW	LEGS Master Pack	—	5,000	A

Pop-Toggle

Base Material: Gypsum Wallboard, Plaster, Plywood, some Hollow Masonry
Size Range: 1/8" to 5/8" Wall Thickness, No. 6 to No. 14 Wood or Sheet Metal Screws
Anchor Material: Plastic



Pop-Toggle fasteners are hollow wall anchors ideal for static applications requiring light duty performance. Installation is easy, needing a predrilled 5/16" diameter hole. The fastener preinstalls without a screw, allowing for easy placement and removal of the fixture.

Item #	Code	Size	Std. Box	Stock*
04060	POW	Small	100	A
04062	POW	Medium	100	A
04064	POW	Large	100	A

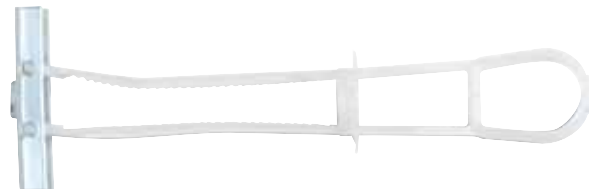

Strap-Toggle™ Hollow Wall Anchor

Base Material: Hollow Wallboard, Hollow Block
Size Range: 3/16" x 4" to 1/2" x 4"
Anchor Material: Plastic

The Strap-Toggle is a preassembled anchor consisting of a carbon steel wing and a locking cap/ratchet leg assembly molded from engineered plastic. When compared to traditional toggles, this unique anchor can be installed through a smaller hole and does not require a fixture or screw to set it.

Item #	Code	Size	Wall Thickness	Drill Dia.	Std. Box	Stock*
4052	POW	3/16" x 4"	2 1/2"	1/2"	50	Y
4054	POW	1/4" x 4"	2 1/2"	1/2"	50	Y
4056	POW	3/8" x 4"	2 1/2"	3/4"	25	Y
4058	POW	1/2" x 4"	2 1/2"	3/4"	25	A

TOGGLER®

Hollow-Wall Anchor

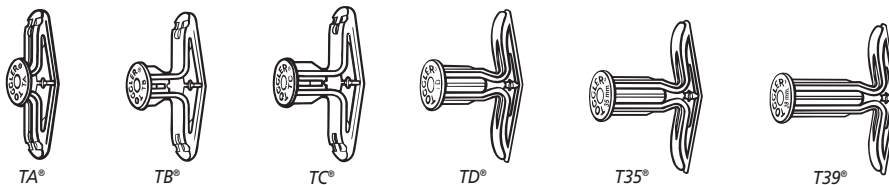

Item #	Code	Grip Range Inches (mm)	Stock*
TA	TOG	1/8 - 1/4 (3 - 6)	A
TB	TOG	3/8 - 1/2 (9 - 13)	A
TC	TOG	5/8 - 3/4 (16 - 19)	Y
TD	TOG	1 (25)	A
T35	TOG	1 3/8 (35)	A
T39	TOG	1 1/2 (39)	A

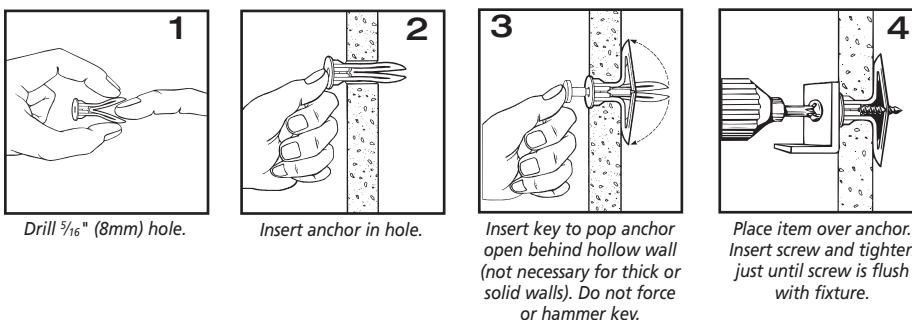

*Y = stock item; A = readily available by order

Epoxy & Tools

AC100+Gold®

AC100+ Gold is a two-component, vinylester, adhesive anchoring system. The system includes injection adhesive in plastic cartridges, mixing nozzles, dispensing tools and hole cleaning equipment. AC100+ Gold is designed for bonding threaded rod and reinforcing bar hardware into drilled holes in concrete and masonry base materials.



CODE LISTED
ICC-ES ESR-2582
Uncracked Concrete

AC100+Gold Cartridge

- One mixing nozzle is packaged with each cartridge

Item #	Code	Size	Std. Box	Std. Ctn.	Stock*
8478SD	POW	10 fl. oz. Quik-Shot Cartridge	1	12	Y
8490SD	POW	28 fl. oz. Dual Cartridge	1	12	Y



8293



8294

AC100+Gold Mixing Nozzle

Item #	Code	Description	Std. Box	Std. Ctn.	Stock*
8293	POW	AC100+Gold Nozzle for 10 oz. Cartridge	2	24	Y
8294	POW	AC100+Gold Nozzle for 28 oz. Cartridge with 8" Extension	2	24	Y



AC100+Gold Dispensing Tool

Item #	Code	Description	Std. Box	Std. Ctn.	Stock*
8494	POW	All-metal Manual Tool for 28 oz. Cartridge	1	—	Y

*Y = stock item; A = readily available by order



T308+™

T308+ is a two-component, epoxy adhesive anchoring system. The system includes injection adhesive in plastic cartridges, mixing nozzles, dispensing tools and hole cleaning equipment. T308+ is designed for bonding threaded rod and reinforcing bar into drilled holes in concrete base materials.



CODE LISTED
ICC-ES ESR-3149
Unreinforced Masonry

CODE LISTED
ICC-ES ESR-3066
Uncracked Concrete

T308+ Cartridge

- One mixing nozzle is packaged with each cartridge

Item #	Code	Size	Std. Box	Std. Ctn.	Stock*
8503SD	POW	14 fl. oz. Side-by-Side Cartridge	12	—	Y
8523SD	POW	21.5 fl. oz. Side-by-Side Cartridge	12	—	Y



T308+ Mixing Nozzle

Item #	Code	Description	Std. Box	Std. Ctn.	Stock*
7908	POW	T308+ Nozzle with 9" Extension Tube	2	24	Y



T308+ Dispensing Tool

Item #	Code	Description	Std. Box	Std. Ctn.	Stock*
8409	POW	All-metal Manual Tool for 21.5 oz. Cartridge	1	—	Y
8416	POW	All-metal Manual Tool for 14 oz. Cartridge	1	—	Y

Hole Cleaning Tools & Accessories

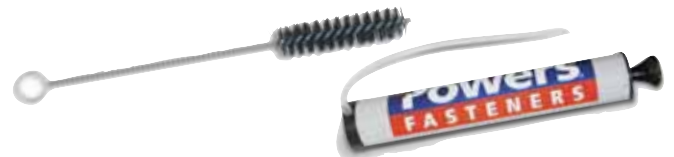

Item #	Code	Size	Std. Box	Std. Ctn.	Stock*
8280	POW	25 oz. Hand Pump/Dust Blower	1	—	Y
7932	POW	3/4" Diameter Nylon Brush	1	—	Y

Epoxy & Tools

Hammer-Capsule®

Drive-In Type Capsule Adhesive

Base Material: Solid Concrete
Size Range: 3/8" to 1" Anchor Rod
 No. 3 to No. 8 Reinforcing Bar
Anchor Material: Ester-Based Resin

The Hammer-Capsule System consists of a self-contained, single use, two-part glass capsule into which threaded anchor rods or reinforcing bars can be directly driven without the need for a chisel point or spinning action.



Item #	Code	Size	Drill Dia.	Min. Depth	Std. Box	Stock*
6702	POW	3/8"	7/16"	3 1/2"	10	A
6703	POW	1/2"	9/16"	4 1/4"	10	Y
6704	POW	5/8"	1 1/16"	5"	10	Y
6705	POW	3/4"	7/8"	6 5/8"	5	Y
6706	POW	7/8"	1"	7"	5	A
6707	POW	1"	1 1/8"	8 1/4"	5	A

CRACK-PAC® Injection Epoxy Kit

Crack-Pac® two-part, high solids, low-viscosity crack injection epoxy is designed to repair cracks in concrete. The mixed adhesive has the viscosity of a light oil and a low surface tension that enables it to penetrate fine to medium width cracks. Resin is contained in the cartridge and hardener is contained in the nozzle. Once the nozzle is threaded onto the cartridge, the hardener is released into the resin-filled cartridge by turning the knob at the base of the nozzle. The two components are mixed by shaking the cartridge.



The Crack-Pac Injection Kit includes everything needed to pressure inject approximately eight lineal feet of cracks:

- (2) Crack-Pac cartridge/nozzle sets
- (12) E-Z-Click injection ports
- (2) E-Z-Click injection fittings with 12" tubing
- (1) Pint of paste-over epoxy (8 oz. of resin + 8 oz. of hardener)
- (4) Disposable wood paste-over applicators
- (1) Pair latex gloves
- Installation video

Item #	Code	Description	Stock*
ETIPAC10KT	SIM	Crack-Pac Injection Epoxy Kit	Y

*Y = stock item; A = readily available by order

Powder Actuated

Powder Load



Specific load types are designed for each unique powder actuated tool. They are offered as single units for single shot tools and collated in groups of 10 into plastic strips or metal discs for semi-automatic tools.

.22 Caliber "A" Low Velocity Load for Powers P7200 & P2200; Ramset® 721 & M70; Hilt® DXE37 & DXE72

Item #	Code	Description	Std. Box	Stock*
50500	POW	Gray	100	A
50502	POW	Brown	100	A
50504	POW	Green	100	A
50506	POW	Yellow	100	A



.25 Caliber Disk Loads for Ramset® D45, D60 & D60L

Item #	Code	Description	Std. Box	Stock*
50532	POW	Brown	100	A
50534	POW	Green	100	A
50536	POW	Yellow	100	A



Safety Strip®

The Safety Strip is molded into a special length to provide a visual indication that the tool is loaded.



.27 Caliber Safety Strip® Load for Powers P3500, PA351, P3600; Ramset® SA270 & Viper; Hilt® DX350, DX36M, DX451 & DX460

Item #	Code	Description	Std. Box	Stock*
50620	POW	Brown	100	A
50622	POW	Green	100	A
50626	POW	Yellow	100	A
50630	POW	Red	100	A

CAUTION

Powder Actuated Tool Operator

Always test-fasten with the tool's lowest power level. If more power is necessary, use the next highest power level until proper level and fastening is achieved. Refer to operator's manual for more specific details. Observe all safety reminders. Tool operator must be trained and qualified as required by federal law. Failure to use properly can result in serious injury or death to user or bystanders.

Powder Actuated

.300 Head Drive Pin

Drive pins with a 0.300 diameter head are designed for permanently fastening a fixture to concrete, some types of masonry, and A36 structural steel. Drive pins are manufactured with a 0.145" diameter shank in various lengths. Knurled shank designs are available to increase performance in steel base materials. A plastic flute is mounted over the point to retain the drive pin in the fastener guide of the tool, providing guidance during the driving operation.



.300 Head Drive Pin—Standard

Item #	Code	Shank Length	Std. Box	Stock*
50012-POW	POW	½" Knurled	100	Y
50016	POW	⅝" Knurled	100	A
50022	POW	¾"	100	A
50023	POW	¾" Black Pins	100	Y
50026	POW	1"	100	A
50030	POW	1⅛"	100	A
50032	POW	1¼"	100	A
50034	POW	1½"	100	A
50036	POW	1¾"	100	A
50038	POW	2"	100	A
50040	POW	2¼"	100	A
50044	POW	2½"	100	A
50046	POW	2¾"	100	A
50048	POW	3"	100	A

.300 Head Drive Pin with Top Hat



Drive pins with top hats are used primarily for fastening drywall track to concrete or steel. The metal top hat provides extra bearing surface against the drywall track.

Item #	Code	Shank Length	Std. Box	Stock*
50136	POW	½" Knurled	100	Y
50138	POW	⅝" Knurled	100	A
50140	POW	¾"	100	A
50144	POW	1"	100	A

.300 Head Drive Pin with ⅞" Washer



To provide resistance to pullover, drive pins are available with preassembled, 14-gauge metal washers in various diameters. The insulation washer has a thickness of 0.035".

Item #	Code	Shank Length	Std. Box	Stock*
50090	POW	1"	100	A
50092	POW	1¼"	100	A
50094	POW	1½"	100	A
50096	POW	2"	100	A
50098	POW	2½"	100	A
50100	POW	3"	100	A



Ballistic Point™ Drive Pin

Premium drive pins with a 0.300 diameter head have a specially designed point to allow more consistent penetration into harder base materials. Manufactured with a 0.150" diameter straight and step shank in various lengths. A plastic flute is mounted over the point to retain the drive pin in the fastener guide of the tool providing guidance during the driving operation.

Ballistic Point Drive Pin—Black

Item #	Code	Shank Length/Dia.	Std. Box	Stock*
50052	POW	½"/.150"	100	A
50054	POW	¾"/.150"	100	A

Ballistic Point Step Shank Drive Pin

Item #	Code	Shank Length - Dia.	Std. Box	Stock*
50056	POW	1¼" - .181/.150"	100	A
50057	POW	1⅝" - .181/.150"	100	A

Ceiling Clip Assemblies

For applications suspending acoustical ceiling systems or light fixtures, several styles of angled clips are premounted onto pins.



8mm Drive Head Pin with Ceiling Clip

Item #	Code	Description	Shank Dia.	Wire Hole	Std. Box	Stock*
50272	POW	27 mm	.143"	.278"	100	A
50274	POW	32 mm	.143"	.278"	100	A



.300 Head Pin with Ceiling Clip

Item #	Code	Description	Shank Dia.	Wire Hole	Std. Box	Stock*
50364	POW	1"	.143"	.278"	100	A
50368	POW	1" (economy clip)	.143"	.278"	100	A
50370	POW	1¼"	.143"	.278"	100	A

*Y = stock item; A = readily available by order

Powder Actuated

.300 Head Drive Pin

ITW Ramset/Red Head powder actuated fasteners are specifically fabricated to meet the exacting requirements of toughness and durability that enable them to penetrate dense concrete and structural quality steel.

- .145 diameter shank
- 100 pins per pack

.300 Head Plated Drive Pin



Item #	Code	Shank Length (mm)	721/R25	Rocket	D60/D45A	SA270	XT540	COBRA	Mastershot/RS22	Stock*
1503K	RAM	½" knurled (12.7)	■	■	■	■	■	■	■	A
1506	RAM	¾" (19.1)	■	■	■	■	■	■	■	A
1508-RAM	RAM	1" (25.4)	■	■	■	■	■	■	■	Y
1510	RAM	1¼" (31.8)	■	■	■	■	■	■	■	Y
1512	RAM	1½" (38.1)	■	■	■	■	■	■	■	Y
1514	RAM	2" (50.8)	■	■	■	■	■	■	■	Y
1516	RAM	2½" (63.5)	■	■	■	■	■	■	■	Y
1524	RAM	3" (76.2)	■	■	■	■	■	■	■	Y

.300 Head Drive Pin with 7/8" Washer

Washer increases bearing surface against the material to be fastened.



Item #	Code	Shank Length (mm)	721/R25	Rocket	D60/D45A	SA270	XT540	COBRA	Mastershot/RS22	Stock*
1506SD	RAM	¾" (19.1)	■	■	■	■	■	■	■	A
1508SD	RAM	1" (25.4)	■	■	■	■	■	■	■	Y
1510SD	RAM	1¼" (31.8)	■	■	■	■	■	■	■	A
1512SD	RAM	1½" (38.1)	■	■	■	■	■	■	■	Y
1514SD	RAM	2" (50.8)	■	■	■	■	■	■	■	A
1516SDC	RAM	2½" (63.5)	■	■	■	■	■	■	■	A
1524SDP	RAM	3" (76.2)	■	■	■	■	■	■	■	A

.300 Head Top Hat Drive Pin

Increases the bearing surface against the material to be fastened for improved attachment to inconsistent base materials.



Item #	Code	Shank Length (mm)	721/R25	Rocket/D45A	SA270	XT540	COBRA	Mastershot/RS22	Stock*
1906	RAM	¾" (19.1)	■	■	■	■	■	■	Y
1908	RAM	1" (25.4)	■	■	■	■	■	■	A

.300 Head PowerPoint Pin

Pins for fastening into harder steel and concrete.



Item #	Code	Shank Length (mm)	721/R25	Rocket	D60/D45A	SA270	XT540	COBRA	Mastershot/RS22	Stock*
SP12-RAM	RAM	½" (12.7)	■	■	■	■	■	■	■	Y
SP58	RAM	⅝" (15.9)	■	■	■	■	■	■	■	A
SP34	RAM	¾" (19.1)	■	■	■	■	■	■	■	Y

.300 Head PowerPoint Step Shank Pin

Pins for fastening into harder steel and concrete.



Item #	Code	Shank Length (mm) / Diameter	721/R25	Rocket	D60/D45A	SA270	XT540	COBRA	Mastershot/RS22	Stock*
SP100	RAM	1" (25.4) / .181/.150"	■	■	■	■	■	■	■	A
SP114	RAM	1¼" (31.8) .181/.150"	■	■	■	■	■	■	■	Y
SP178	RAM	1⅝" (47.6) .181/.150"	■	■	■	■	■	■	■	Y



Powder Actuated



Ceiling Clip Assemblies

Fastener is preassembled to angle clip for applications such as hanging ceiling wire to support ceiling grid.

- .300 head diameter pin
- .145 shank diameter
- 100 pins per pack

Item #	Code	Pin Length (mm)	721	Rocket/SA270	Viper	XT540	COBRA	D60	D45A	Stock*
SDC100 (1,000/pk.)	RAM	1" (25.4)	■	■	■	■	■	■	■	A
SDC125C	RAM	1¼" (31.8)	■	■	■	■	■	■	■	Y



Powder Load

ITW Ramset/Red Head powder loads and tools match tolerances to provide optimum power within recognized national velocity standards. Available in color-coded 10-load discs, 10-load strips, and 100-load boxes.

Power level is designated by the load level number marked on each box. As the number increases, the power level increases. Power level is also designated by the color of the box and each powder load.



Ramset Loads for Low Velocity Tools

Item #	Code	Stock*	Power Level	Color	Caliber	Packaging	Ramset Tool Model	Other Tool Model
2D60	RAM	Y	2	Brown	.25	All 10-disc, 10 Discs/Box	D60, D45 & AutoFast	
3D60	RAM	Y	3	Green	.25			
4D60	RAM	Y	4	Yellow	.25			
5D45	RAM	A	5	Red	.25	10 Discs/Box	D45 & AutoFast	
22CW	RAM	Y	2	Brown	.22	All 100/Box	721, M70, RS22, HD22, Mastershot	DXE37, DXE72
32CW	RAM	Y	3	Green	.22			
42CW	RAM	Y	4	Yellow	.22			
3RS25	RAM	A	3	Green	.25	All 10-strip, 10 Strips/Box	R25	DX-35
4RS25	RAM	A	4	Yellow	.25			
5RS25	RAM	A	5	Red	.25			
3RS27	RAM	Y	3	Green	.27	All 10-strip, 10 Strips/Box	SA270, Cobra, Viper, Rocket & XT540	DX-350, DX-351, DX-36M, DX460
4RS27	RAM	Y	4	Yellow	.27			
5RS27	RAM	Y	5	Red	.27			DX-350, DX-351, DX-36M, DX-451, DX460

CAUTION

Powder Actuated Tool Operaton

Always test-fasten with the tool's lowest power level. If more power is necessary, use the next highest power level until proper level and fastening is achieved. Refer to operator's manual for more specific details. Observe all safety reminders. Tool operator must be trained and qualified as required by federal law. Failure to use properly can result in serious injury or death to user or bystanders.

Visit our Rental
Department or Web
site for details on
renting Air Nailers,
Staplers and
Accessories

*Y = stock item; A = readily available by order

Powder Actuated Tools



SA270 .27 Caliber Strip Tool

- Semi-automatic
- Power adjust
- Rubber grip on front barrel eliminates pinched fingers and hands
- Twist lock front end is easy to clean
- Soft, recoil-absorbing handle for increased operator comfort
- Muzzle bushing O.D.: 5/8"



Item #	Code	Description	Weight	Maximum Pin Capacity	Stock*
SA270	RAM	10-shot strip loads: 3 (green), 4 (yellow), 5 (red)	5 3/4 lb.	3" straight pin	Y

Viper .27 Caliber Strip Tool

- Automatic load advance and piston return
- Designed specifically for overhead applications
- Overdrive protection prevents front end damage caused by piston overdrive



Item #	Code	Description	Weight	Maximum Pin Capacity	Stock*
VIPER	RAM	10-shot strip loads: 3 (green), 4 (yellow), 5 (red)	4 1/2 lb.	1 1/2"	A

Mastershot .22 Caliber Single Shot Tool

- Trigger operated
- Positive barrel and load retention prevents barrel from opening freely, allowing easy horizontal and overhead fastening
- Powder load ejects easily after each use
- Muzzle bushing O.D.: 3/4"



Item #	Code	Description	Weight	Max. Pin Capacity	Stock*
MASTERSHOT	RAM	Single shot loads: 2 (brown), 3 (green), 4 (yellow)	4 1/4 lb.	3"	Y

Gas Actuated

Trak-It® Fasteners & Fuel Cell

Base Material: Concrete, Block, A36 Steel
Size Range: 1/2" to 1 1/2" Pin Lengths
Anchor Material: Carbon Steel

Trak-It Fasteners and the Trak-It Fuel Cell are designed to be used with the Powers Trak-It tool and the ITW Ramset® TrakFast™ tool**. Ten fasteners are collated on each patented, plastic top hat-style strip. Use for light duty static applications such as drywall track to concrete, block or steel, lath to concrete or block, furring strips to concrete or block, and plywood to concrete or block base materials.

The fuel cell contains enough gas to install up to 1,200 fasteners.

Each box includes 1,000 pins and one fuel cell.

**Ramset® is a registered trademark of Illinois Tool Works, Inc.; TrakFast™ is a trademark of Illinois Tool Works, Inc.



Item #	Code	Description	Stock*
55020	POW	1/2" Trak-It® Steel Pins & Fuel Cell	A
55022B	POW	3/4" Trak-It® Black Pins & Fuel Cell	A
55024	POW	1" Trak-It® Zinc Pins & Fuel Cell	A
55026	POW	1 1/4" Trak-It® Zinc Pins & Fuel Cell	Y
55028	POW	1 1/2" Trak-It® Zinc Pins & Fuel Cell	A
55010	POW	Trak-It® Fuel Cell	Y

*Y = stock item; A = readily available by order

Gas Actuated

TrakFast TF1200 Tool and Accessories

Easy to use and 3-5x faster than powder tools

TrakFast's ease of use and productivity comes from the tool's battery and fuel cell. The 6-volt rechargeable Ni-CD battery can drive approximately 3,000 shots per charge. The clean burning fuel cell can drive over 1,000 pins and keeps the tool cleaner than powder actuated tools.

- Fully automatic
- 1½" pin capacity
- 42-pin magazine capacity
- 17½" length; 15" height; 7.9 lb.
- Maximum cycles/second: 2

Item #	Code	Description	Stock*
TF1200	RAM	TrakFast TF1200 Tool	Y
TFUEL	RAM	Fuel Cell	Y
7505012	RAM	Battery Cell	Y
7505142	RAM	Charger	A
LD100	RAM	1,000 Pack Plated Lathing Discs (1" diameter)	A
7405140	RAM	Disc Holding Probe (for TF1000)	A
7405151	RAM	Disc Holding Probe (for TF1100)	A
7405160	RAM	Delta Plug Holder/Cosella	A
7405162	RAM	Platen Plug Holder/Big O	A



Breakaway Collation Pin Strip & Fuel Pack

Designed for applications that require the head of the fastener to be flush or slightly recessed with the surface of the material being attached. Collation strip breaks away upon impact, allowing the head to recess into the material. Pins work in both concrete and block without making adjustments to the power of the tool.

Each fuel & pin pack includes
1 FUEL CELL & 1,000 PINS.

Item #	Code	Description	Stock*
FPP034T	RAM	¾" Plated Pin	A
FPP100T	RAM	1" Plated Pin	A
FPP114T	RAM	1¼" Plated Pin	A
FPP112-1M	RAM	1½" Plated Pin	Y

Standard Black Collation Pin Strip & Fuel Pack

TrakFast's patented black collation strip is designed to stay with the fastener. Track or channels are held down tightly to the work surface. Pins work in both concrete and block without making any adjustments to the power of the tool.

Item #	Code	Description	Stock*
FPP012-1M	RAM	½" Plated Steel Pin	Y
FPP034B-1M	RAM	¾" Black Pin	Y
FPP100B	RAM	1" Black Pin	A
FPP114-1M	RAM	1¼" Plated Pin	Y

Mechanical Fastening Accessories

½" Straight Shank Pin

Used for fastening sheet metal to steel.

¾" Straight Shank Pin

Used for attaching to block, pan and most grades of concrete.

¾" Step Shank Pin

Premium pin with ballistic "bunker buster" profile for hard concrete applications.

1" Straight Shank Pin

Used when deeper embedment is required (pan deck, insulated fireproofing, etc.).

1" PowerPoint® Step Shank Pin

Used when maximum holding strength is required.



Item #	Code	Description	Box Qty.	Stock*
MP012	RAM	½" Pin with gold domed washer	800 Pins/1Fuel Cell	A
MP034	RAM	¾" Pin with domed washer	800 Pins/1Fuel Cell	Y
MO34BB	RAM	¾" Step Pin with domed washer	800 Pins/1Fuel Cell	A
MP100	RAM	1" Pin with gold domed washer	800 Pins/1Fuel Cell	A
SP100 SMD	RAM	1" Pin with gold domed washer & Plastic Flute	100 Pins	A

*Y = stock item; A = readily available by order

Rivets

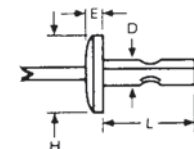

Buttonhead

Steel Buttonhead Rivet

- Plated-steel Rivet • Coated Steel Mandrel • IFI Grade 30

Item #	Code	D Rivet Dia. Nom. Inch	Drill No.	H Head Dia. Nom. Inch	E Head Height Max. Inch	L Rivet Length Max. Inch (mm)	Grip Range Inch (mm)	Typical Ultimate Strength Shear / Tensile (lb.)	Qty.	Stock*
SB4-1	RIV	1/8 (.094) (3.2 mm)	#30 (.129-.133) (3.3 mm /3.28-3.38 mm)	.250 (6.35 mm)	.040 (1.02 mm)	.212 (5.4)	.032-.062 (0.8-1.6)	305 / 410	500	A
SB4-2	RIV					.275 (7.0)	.063-.125 (1.7-3.2)	305 / 410	500	A
SB4-3	RIV					.337 (8.6)	.126-.187 (3.3-4.8)	305 / 410	500	A
SB4-4	RIV					.400 (10.2)	.188-.250 (4.9-6.4)	305 / 410	500	A
SB4-5	RIV					.462 (11.7)	.251-.312 (6.5-7.9)	305 / 410	500	A
SB46-500	RIV					.525 (13.4)	.313-.375 (8.0-9.5)	305 / 410	500	Y
SB4-8	RIV					.650 (16.5)	.376-.500 (9.6-12.7)	305 / 410	500	A
SB4-10	RIV					.775 (19.7)	.501-.625 (12.8-15.9)	305 / 410	500	A

Aluminum Buttonhead Rivet

- 5052 Aluminum Rivet • Aluminum Mandrel • IFI Grade 11

Item #	Code	D Rivet Dia. Nom. Inch	Drill No.	H Head Dia. Nom. Inch	E Head Height Max. Inch	L Rivet Length Max. Inch (mm)	Grip Range Inch (mm)	Typical Ultimate Strength Shear / Tensile (lb.)	Qty.	Stock*				
AB4-1A	RIV	1/8 (.094) (3.2 mm)	#30 (.129-.133) (3.3 mm /3.28-3.38 mm)	.250 (6.35 mm)	.040 (1.02 mm)	.212 (5.4)	.032-.062 (0.8-1.6)	155 / 240	500	A				
AB42A-500	RIV					.275 (7.0)	.063-.125 (1.7-3.2)	155 / 240	500	Y				
AB4-3A	RIV					.337 (8.6)	.126-.187 (3.3-4.8)	155 / 240	500	A				
AB4-4A	RIV					.400 (10.2)	.188-.250 (4.9-6.4)	155 / 240	500	A				
AB4-5A	RIV					.462 (11.7)	.251-.312 (6.5-7.9)	155 / 240	500	A				
AB4-6A	RIV					.525 (13.4)	.313-.375 (8.0-9.5)	155 / 240	500	A				
AB4-8A	RIV					.650 (16.5)	.376-.500 (9.6-12.7)	155 / 240	500	A				
AB4-10A	RIV					.775 (19.7)	.501-.625 (12.8-15.9)	155 / 240	500	A				
AB6-2A	RIV					3/16 (.094) (4.8 mm)	#11 (.192-.196) (4.9 mm /4.88-4.98 mm)	.375 (9.53 mm)	.060 (1.52 mm)	.325 (8.3)	.062-.125 (1.6-3.2)	330 / 515	500	A
AB64A-500	RIV									.450 (11.5)	.126-.250 (3.3-6.4)	330 / 515	500	Y
AB64AC-5M	RIV	.450 (11.5)	.126-.250 (3.3-6.4)	330 / 515	5,000					Y				
AB6-6A	RIV	.575 (14.6)	.251-.375 (6.5-9.5)	330 / 515	500					A				
AB6-8A	RIV	.700 (17.8)	.376-.500 (9.6-12.7)	330 / 515	500					A				
AB6-10A	RIV	.825 (21.0)	.501-.625 (12.8-15.9)	330 / 515	500					A				
AB6-12A	RIV	.950 (24.2)	.626-.750 (16.0-19.1)	330 / 515	500					A				
AB6-14A	RIV	1.075 (27.3)	.751-.875 (19.1-22.2)	330 / 515	500					A				
AB6-16A	RIV	1.200 (30.5)	.751-1.000 (19.1-25.4)	330 / 515	500					A				
AB6-20A	RIV	1.450 (36.8)	1.125-1.250 (28.6-31.8)	330 / 515	500					A				

*Y = stock item; A = readily available by order

Rivet Tools



HP-2® Hand Rivet Tool

- Precision die cast, high strength aluminum alloy body
- Drop-forged carbon steel upper handle
- Thick, cushion-molded vinyl grips for comfort
- Sets up to 3/16" steel rivets
- Comes with four mounted nosepieces (3/32", 1/8", 5/32", 3/16") and a service wrench

Item #	Code	Description	Stock*
39000	RIV	HP-2 Hand Rivet Tool	Y

Big Daddy® Hand Rivet Tool

- Extra-long handles provide excellent leverage and permits working a foot beyond natural reach
- Double gear reduction system sets from 1/8" to 1/4" diameter Klik-Fast rivets in all alloys, including 1/4" Klik-Split® rivets
- One-piece collet case eliminates the need to adjust the tool when changing rivet diameters
- Comes with three nosepieces (3/32", 3/16", 1/4"), which are stored in the body



Item #	Code	Description	Stock*
39031	RIV	Big Daddy Hand Rivet Tool	Y



M-3 Air/Hydraulic Rivet Tool

- Steel forged head allows for continuous full operating power and less internal wear
- Recommended airline pressure: 85-95 psi
- Sets blind rivets from 1/8" to 3/16" diameter in all materials
- Comes with standard 1/8", 5/32" and 3/16" nosepieces, service wrench, swivel inlet air coupler and a mandrel collection bottle

Item #	Code	Description	Stock*
39054	RIV	M-3 Air/Hydraulic Rivet Tool	Y



302-E Air/Hydraulic Rivet Tool

- Fully adjustable vacuum system holds the rivet in the nosepiece, allowing the operator to rivet at any angle with one hand free, and automatically collects the spent mandrel into a collection bottle
- Recommended airline pressure: 85-95 psi
- Sets rivets from 3/32" to 3/16" diameter in all alloys and sets 1/4" diameter open-end rivets in aluminum/steel combination

Item #	Code	Description	Stock*
39062	RIV	302-E Air/Hydraulic Rivet Tool	N

Specialty



PORTA-NAILER®

16 Gauge Manual Floor Nailer

- Uses T flooring nails/cleats
- Ratcheting ram allows for single or multiple hits
- Nonmarring hammer
- Includes carrying case and instructional DVD



PORTA-NAILS® 16 Gauge T Nails

- Wide-head design gives greater impact and holding power
- Coverage is approximately 1,000 nails per 200 square feet of standard 2 1/2" strip flooring

Item #	Code	Description	Stock*
402-POR	POR	Porta-Nailer Floor Nailer	Y
42623	POR	2" Porta-Nails - 1,000 nails per box	Y

16 gauge L Head Flooring Cleat Nails

Bright Basic Finish



Item #	Code	Size	Qty	Stock*
RW21BPE-1M	SEN	2"	1M	Y



Plasti-Top Cap Roofing Nails

Item #	Code	Size	Gauge	Description	Box	Stock*
136070-2.8M	HIT	1 1/4"	12	Ring Shank, Galvanized	2.8M	Y

*Y = stock item; A = readily available by order

Nails

Common Nail - Smooth Shank

Flat head. Diamond point. The most popular group of nails, use common nails for general carpentry and framing projects.

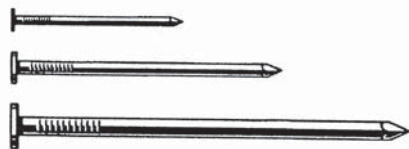

50-lb. Box

Item #	Code	Size	Length	Gauge	Head	Approx. Count/Lb.	Stock*
3D-50	NAI	3d	1¼"	14	1³⁄₆₄"	543	A
4D-50	NAI	4d	1½"	12½	¼"	294	A
6D-50	NAI	6d	2"	11½	17⁄₆₄"	167	Y
8D-50	NAI	8d	2½"	10¼	9⁄₃₂"	101	Y
10D-50	NAI	10d	3"	9	5⁄₁₆"	66	Y
12D-50	NAI	12d	3¼"	9	5⁄₁₆"	61	Y
16D-50	NAI	16d	3½"	8	11⁄₃₂"	47	Y
20D-50	NAI	20d	4"	6	13⁄₃₂"	29	A
30D-50	NAI	30d	4½"	5	7⁄₁₆"	22	A
40D-50	NAI	40d	5"	4	15⁄₃₂"	17	A
50D-50	NAI	50d	5½"	3	½"	13	A
60D-50	NAI	60d	6"	2	17⁄₃₂"	10	A

Duplex Nail

Double flat head. Diamond point. Smooth shank. The bottom head acts as a stop to make it easy to remove the nail and dismantle temporary structures without damaging the lumber. Use duplex nails for scaffolds, framework and other temporary structures.

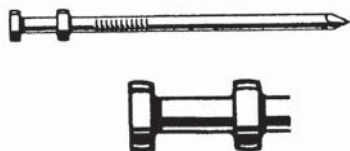

50-lb. Box

Item #	Code	Size	Length	Gauge	Head	Approx. Count/Lb.	Stock*
6DD-50	NAI	6d	2¼"	11½	3⁄₁₆"	156	A
8DD-50	NAI	8d	25⁄₈"	10¼	15⁄₆₄"	90	Y
10DD-50	NAI	10d	33⁄₁₆"	9	¼"	59	A
16DD-50	NAI	16d	3½"	8	9⁄₃₂"	45	Y

Sinker

Flat countersunk head. Diamond point. Smooth shank. Vinyl coated to lubricate and then bind. Sinkers, which feature a thin shank to reduce wood splitting, have hundreds of carpentry uses.

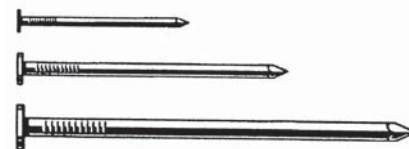

50-lb. Box

Item #	Code	Size	Length	Gauge	Head	Approx. Count/Lb.	Stock*
3DCS-50	NAI	3d	1⅛"	15½	11⁄₆₄"	923	A
4DCS-50	NAI	4d	1⅜"	14	13⁄₆₄"	527	A
5DCS-50	NAI	5d	1⅝"	13½	7⁄₃₂"	387	A
6DCS-50	NAI	6d	17⁄₈"	13	15⁄₆₄"	293	Y
8DCS-50	NAI	8d	2⅜"	11½	17⁄₆₄"	153	Y
10DCS-50	NAI	10d	27⁄₈"	11	9⁄₃₂"	111	A
12DCS-50	NAI	12d	3⅜"	10	5⁄₁₆"	81	Y
16DCS-50	NAI	16d	3¼"	9	11⁄₃₂"	64	A
20DCS-50	NAI	20d	3¾"	7	3⁄₈"	40	A

Hardened Fluted Nail

Flat head. Diamond point. Fluted shank. The fluted shank rotates and bores into concrete for stronger holding power. Temper hardened steel is used to survive powerful hammer blows. Use for nailing lumber to concrete and masonry.

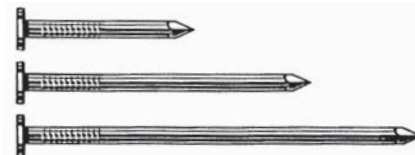

50-lb. Box

Item #	Code	Length	Gauge	Head	Approx. Count/Lb.	Stock*
CON34-50	NAI	¾"	9	11⁄₃₂"	190	A
CON1-50	NAI	1"	9	11⁄₃₂"	169	Y
CON114-50	NAI	1¼"	9	11⁄₃₂"	149	A
CON112-50	NAI	1½"	9	11⁄₃₂"	128	Y
CON134-50	NAI	1¾"	9	11⁄₃₂"	110	A
CON2-50	NAI	2"	9	11⁄₃₂"	98	Y
CON212-50	NAI	2½"	9	11⁄₃₂"	88	Y
CON234-50	NAI	2¾"	9	11⁄₃₂"	79	A

Check out shock resistant hammers on page 86.



*Y = stock item; A = readily available by order

Collated Nails

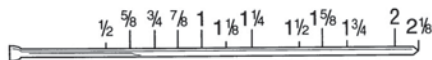

18 Gauge Galvanized Brad Nails

Standard Box 5M



Item #	Code	Size	Stock*	Fits These Tools
AX10EAA	SEN	5/8"	A	SENCO LS4, FinishPro Series, SLP20, AccuSet A125BN, A200BN, A2N125, Craftsman 18424, DeWalt D51238, Porter-Cable BN125, BN200
AY10EAA-5M	SEN	5/8"	Y	SENCO FinishPro25, SLP20
AX11EAA	SEN	3/4"	A	SENCO LS4, FinishPro Series, SLP20, AccuSet A125BN, A200BN, A2N125, Bostitch BT35, DeWalt D51238
AY11EAA-5M	SEN	3/4"	Y	SENCO SLP20
AX13EAA-5M	SEN	1"	Y	SENCO LS4, FinishPro Series, SLP20, AccuSet A125BN, A200BN, A2N125, Bostitch BT35, Craftsman 18424, DeWalt D51238, Duo-Fast BB440, Hitachi NT45A, Paslode 2138-F18, Porter-Cable BN125, BN200
AX15EAA-5M	SEN	1 1/4"	Y	SENCO FinishPro Series, SLP20, AccuSet A125BN, A200BN, A2N125, Craftsman 18424, DeWalt D51238, Porter-Cable BN125, BN200
AX17EAA-5M	SEN	1 1/2"	Y	SENCO FinishPro Series, SLP20, AccuSet A200BN, Bostitch BT50, Craftsman 18424, DeWalt D51238, Hitachi NT45A, Porter-Cable BN200
AX18EAA-5M	SEN	1 5/8"	Y	SENCO FinishPro Series, SLP20, AccuSet A200BN, Craftsman 18424
AX19EAA	SEN	1 3/4"	A	SENCO FinishPro25, AccuSet A200BN, Bostitch BT50, DeWalt D51238, Porter-Cable BN200
AX21EAA-5M	SEN	2"	Y	SENCO FinishPro Series, AccuSet A200BN, Bostitch BT50, Craftsman 18424, DeWalt D51238, Porter-Cable BN200
AX22EAA	SEN	2 1/8"	A	SENCO FinishPro Series

These tools use the above nails

Senco
SLP20Bostitch
BT50Bostitch
BT35Duo-Fast
BB440Hitachi
NT45APaslode
2138-F18Porter-Cable
BN125Porter-Cable
BN200

Additional tools:

- Senco FinishPro Series
- Senco LS4
- **AccuSet** A125BN
- **AccuSet** A200BN
- **AccuSet** A2N125
- **DeWalt** D51238

*Y = stock item; A = readily available by order

Utica 315-724-7119

Watertown 315-788-2612

Syracuse 315-671-4400



18 Gauge Galvanized Straight Brad Nails



Item #	Code	Size	Shank	Box	Stock*
650212-2M	PAS	1"	Smooth	2M	Y
650213-2M	PAS	1 1/4"	Smooth	2M	Y
650214-2M	PAS	1 1/2"	Smooth	2M	Y
650215-2M	PAS	2"	Smooth	2M	Y

16 Gauge Galvanized Straight Finish Nails

Fits Paslode

902000 & 501680

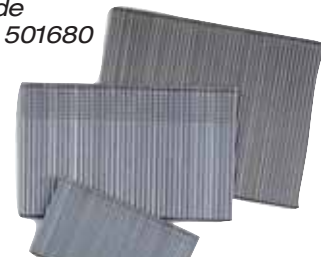

Item #	Code	Size	Box	Stock*
650282-2M	PAS	1 1/4"	2M	Y
650283-2M	PAS	1 1/2"	2M	Y
650284-2M	PAS	1 3/4"	2M	Y
650285-2M	PAS	2"	2M	Y
650287-2M	PAS	2 1/2"	2M	Y

16 Gauge Galvanized Angled Finish Nails

Fits Paslode 90600 & 500910



Item #	Code	Size	Box	Stock*
650230-2M	PAS	1 1/4"	2M	Y
650231-2M	PAS	1 1/2"	2M	Y
650046	PAS	1 3/4"	2M	A
650047-2M	PAS	2"	2M	Y
650232-2M	PAS	2 1/2"	2M	Y

Collated Nails



15 Gauge 34° Angled Finish Nails

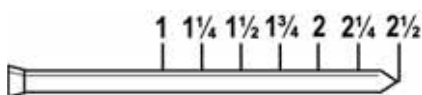

Item #	Code	Size	Finish	Std. Box	Stock*
DA13EPBN†	SEN	1"	Bright Basic	4M	A
DA15EABN	SEN	1 1/4"	Galvanized	4M	A
DA15EPBN-4M	SEN	1 1/4"	Bright Basic	4M	Y
DA17EABN-4M	SEN	1 1/2"	Galvanized	4M	Y
DA17EPBN-4M	SEN	1 1/2"	Bright Basic	4M	Y
DA19EABN	SEN	1 3/4"	Galvanized	4M	A
DA19EPBN-4M	SEN	1 3/4"	Bright Basic	4M	Y
DA21EABN-4M	SEN	2"	Galvanized	4M	Y
DA21EPBN-4M	SEN	2"	Bright Basic	4M	Y
DA21EGBN-2M	SEN	2"	Stainless	2M	Y
DA23EPBN**	SEN	2 1/4"	Bright Basic	4M	A
DA25EAB-3M**	SEN	2 1/2"	Galvanized	3M	Y
DA25EPB-3M**	SEN	2 1/2"	Bright Basic	3M	Y
DA25EGB-1.2M	SEN	2 1/2"	Stainless	1.2M	Y

†SENCO SFN1 & SFN30 only
 **Does not fit SENCO SFN1 or SFN30

These tools use the above nails



Senco SFN1



Senco SFN30



Senco SFN40



Porter-Cable DA250A

Additional tools:

- Senco SFN2B
- Accuset A250FN
- Craftsman 18432
- DeWalt D51275K
- Senco Air Free 41
- Senco Finish Pro 41XP



STANLEY BOSTITCH



15 Gauge Angled Finish Nails

Item #	Code	Size	Finish	Std. Box	Stock*	Fits These Tools
FN1524-3.6M	BST	1 1/2"	Galvanized	3.6M	Y	BOSTITCH N59FN, N60FN, N62FN
FN1532-3.6M	BST	2"	Galvanized	3.6M	Y	
FN1540-3.6M	BST	2 1/2"	Galvanized	3.6M	Y	

16 Gauge Straight Finish Nails



Item #	Code	Size	Box	Stock*
712200	NN	3/4"	5M	A
712250	NN	1"	5M	A
712300	NN	1 1/4"	5M	A
712375	NN	1 1/2"	2.5M	A
712450	NN	1 3/4"	2.5M	A
712500-2.5M	NN	2"	2.5M	Y
712550-2.5M	NN	2 1/4"	2.5M	Y
712600	NN	2 1/2"	2.5M	A

These nails fit:

- Bostich BT31-1B
- Bostich BT35B
- Bostich BT50B
- Bostich SB-1842BN
- Bostich SB-1850BN
- Bostich T29-30
- Duo-Fast BB4440
- Duo-Fast DBN 4052S
- EZ F18/32
- EZ F18/32S
- EZ F 18/40A
- EZ F18/40S
- Fasco F20P GN-31 CT
- Fasco F20T GN-40 CT
- Fasco R3C GN-50 CT
- Haubold SKN30JN/1
- Hilti BN136B
- Hitachi NT45A
- Hitachi NT50AD
- Makita AF502
- Max NF201/18-25
- Max NF211/18-25
- Max NF211/18-50
- Paslode F18-238
- Porter Cable BN125
- Porter Cable BN200
- Prebena 2F-J-32-SD
- Prebena 2K-J-32-SD
- Prebena 2M-J-45-SDS
- Senco SDN18-BR
- Senco SLP20
- Spotnail CB1820
- Spotnail CB1832
- Spotnail DB1825
- Stan-Tech SDN18BR
- Supco1832
- Supco1850
- Unitech 1504

23 Gauge Galvanized Straight Micro Pins



Item #	Code	Size	Box	Stock*
A100509-1M	SEN	1/2"	1M	Y
A100629-2.6M	SEN	5/8"	2.6M	Y
A100759-2.6M	SEN	3/4"	2.6M	A
A101009-2.6M	SEN	1"	2.6M	Y



*Y = stock item; A = readily available by order

Collated Nails

20° Full Round Head Framing Nails

Plastic Collated

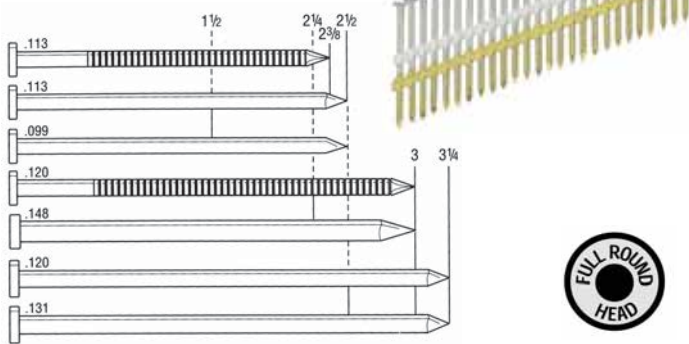

Item #	Code	Size	Shank	Finish	Qty	Stock*
GD21APBSN-5M	SEN	2" x .113	Smooth	Bright Basic	5M	Y
GL21APBSN	SEN	2" x .113	Ring	Bright Basic	5M	A
MD23APBSN	SEN	2 1/4" x .148	Smooth	Bright Basic	4M	A
GD24APBSN-5M	SEN	2 3/8" x .113	Smooth	Bright Basic	5M	Y
GL24APBSN-5M	SEN	2 3/8" x .113	Ring	Bright Basic	5M	Y
M002042-2.5M	SEN	2 3/8" x .113	Ring	Galvanized	2.5M	Y
GL24AABS-5M	SEN	2 3/8" x .113	Ring	Galvanized	5M	Y
GD25AABS	SEN	2 1/2" x .113	Smooth	Galvanized	5M	A
GD25APBSN	SEN	2 1/2" x .113	Smooth	Bright Basic	5M	A
KD25APBSN	SEN	2 1/2" x .131	Smooth	Bright Basic	4M	A
KD27APBSN-4M	SEN	3" x .131	Smooth	Bright Basic	4M	Y
KD27ASBS-2.5M	SEN	3" x .131	Smooth	Hot Dipped	2.5M	Y
KD27AABS	SEN	3" x .131	Ring	Galvanized	4M	A
KD27APBSN	SEN	3" x .131	Smooth	Bright Basic	4M	A
KD27AABS	SEN	3" x .131	Smooth	Galvanized	4M	A
MD27APBSN**	SEN	3" x .148	Smooth	Bright Basic	4M	A
KD28APBSN-4M	SEN	3 1/4" x .131	Smooth	Bright Basic	4M	Y
KD28AABS	SEN	3 1/4" x .131	Smooth	Galvanized	4M	A
KD29APBSN-4M	SEN	3 1/2" x .131	Smooth	Bright Basic	4M	Y
KD29AABS	SEN	3 1/2" x .131	Smooth	Galvanized	4M	A

**For use in SENCO SN65C, FramePro 750XL FRH and 752XP

These tools use the above nails



Additional tools:

- Senco FramePro 602 / 652
- 702XP / 752XP
- Senco Sn65 / 65C
- Bostitch N90RHN
- DeWalt D51845
- Hitachi NR83A
- Paslode 5324SRH

34° Clipped Head Framing Nails

Paper Tape Collated

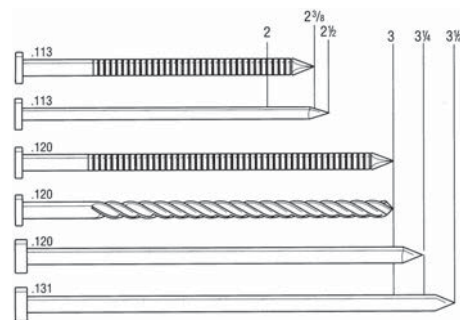

Item #	Code	Size	Shank	Finish	Qty	Stock*
GC21APBK-2.5M**	SEN	2" x .113	Smooth	Bright Basic	2.5M	Y
GC24APBKN-2.5M	SEN	2 3/8" x .113	Smooth	Bright Basic	2.5M	Y
GC24ASBK-2M	SEN	2 3/8" x .113	Smooth	Hot Dipped	2M	Y
GE24AABKN-2.5M	SEN	2 3/8" x .113	Ring	Galvanized	1M	Y
GE24APBK	SEN	2 3/8" x .113	Ring	Bright Basic	5M	A
GC25AABKN-5M	SEN	2 1/2" x .113	Smooth	Galvanized	5M	Y
GC25APBK-5M	SEN	2 1/2" x .113	Smooth	Bright Basic	5M	Y
HC27AABK	SEN	3" x .120	Smooth	Galvanized	3M	A
HC27APBKN	SEN	3" x .120	Smooth	Bright Basic	3M	A
HE27AABKN	SEN	3" x .120	Ring	Galvanized	1M	A
KC27APBK-3M	SEN	3" x .131	Smooth	Bright Basic	3M	Y
KC27ASBK-2M	SEN	3" x .131	Smooth	Hot Dipped	2M	Y
KC28AABK-3M	SEN	3 1/4" x .131	Smooth	Galvanized	3M	Y
KC28AGBK-1M	SEN	3 1/4" x .131	Smooth	Stainless	1M	Y
KC28APBK-3M	SEN	3 1/4" x .131	Smooth	Bright Basic	3M	Y
HC28APBKN	SEN	3 1/4" x .120	Smooth	Bright Basic	3M	A
KC29AABK-3M†	SEN	3 1/2" x .131	Smooth	Galvanized	3M	Y
KC29APBK-3M*†	SEN	3 1/2" x .131	Smooth	Bright Basic	3M	Y

**Block out required for SENCO SN70/SN4

† Does not fit SENCO SN325, SENCO SN325+, Paslode 5325S, PaslodelM325

These tools use the above nails



Additional tools:

- Senco SN4
- Senco FramePro 650
- 601 / 651
- 700 / 750
- 701XP / 751XP
- DeWalt D51823
- Hitachi NR83A
- Paslode 5350S
- Paslode IM325
- Paslode F350S/S
- Paslode 5325S
- Porter-Cable FC350

*Y = stock item; A = readily available by order

Collated Nails



31° Clipped Head Framing Nails

Paper Collated Strip Nails



Item #	Code	Size	Gauge	Description	Box	Stock*
634150-2M	NN	2 3/8"	.113	Ring Shank, Galvanized	2M	Y
631170	NN	3"	.120	Ring Shank, Galvanized	2.5M	A
634180-2M	NN	3 1/4"	.120	Ring Shank, Galvanized	2M	Y

Coated Paper Collated Strip Nails

Item #	Code	Size	Gauge	Description	Box	Stock*
600130-5M	NN	2"	.113	Smooth	5M	Y
602130	NN	2"	.113	Ring Shank	5M	A
600150-5M	NN	2 3/8"	.113	Smooth	5M	Y
602150-5M	NN	2 3/8"	.113	Ring Shank	5M	Y
600170-2.5M	NN	3"	.131	Smooth	2.5M	Y
600171	NN	3"	.120	Smooth	2.5M	A
600190-2.5M	NN	3 1/4"	.131	Smooth	2.5M	Y
600191	NN	3 1/4"	.120	Smooth	2.5M	A

31° CH Framing Nails Fit:

- Hitachi NR83AA
- Paslode Impulse 300
- Paslode Impulse 325
- Paslode SK312
- Paslode 5300
- Paslode 5325
- Paslode 5350
- Porter Cable FC350
- Senco Framepro 600/650
- Senco SN-2
- Senco SN2+
- Senco SN-325
- Senco SN-4
- Senco SN-70
- Senco 701XP
- Senco 751XP
- Senco 700XL
- Senco 750XL

22° Round Head Framing Nails

Coated Plastic Collated Strip Nails



Item #	Code	Size	Gauge	Description	Box	Stock*
616130	NN	2"	.113	Smooth	6M	A
702130	NN	2"	.113	Drive Screw	6M	A
710130	NN	2"	.113	Ring Shank	6M	A
702140	NN	2 1/4"	.113	Drive Screw	5M	A
616150-5M	NN	2 3/8"	.113	Smooth	5M	Y
702150	NN	2 3/8"	.113	Drive Screw	5M	A
710150-5M	NN	2 3/8"	.113	Ring Shank	5M	Y
807150-5M	NN	2 3/8"	.113	Ring Shank, Galvanized	5M	Y
616170-4M	NN	3"	.131	Smooth	4M	Y
616171	NN	3"	.120	Smooth	4M	A
703170	NN	3"	.120	Drive Screw	4M	A
616190-4M	NN	3 1/4"	.131	Smooth	4M	Y
616191	NN	3 1/4"	.120	Smooth	4M	A
703180	NN	3 1/4"	.120	Drive Screw	4M	A
809191-4M	NN	3 1/4"	.120	Drive Screw, Galvanized	4M	Y



28° Framing Nails Wire Collated Strip Nails

Item #	Code	Description	Length	Std. Box	Stock*
S6D-2M	BST	.113 Plain Shank, Coated	6d - 2"	2M	Y
S6DGAL-2M	BST	.113 Plain Shank, Galvanized	6d - 2"	2M	A
S6DR113-2M	BST	.113 Ring Shank, Coated	6d - 2"	2M	A
S6DR113GAL	BST	.113 Ring Shank, Galvanized	6d - 2"	2M	A
S8DFH	BST	.131 Plain Shank, Coated	8d - 2 1/2"	2M	Y
S8D131GAL	BST	.131 Plain Shank, Galvanized	8d - 2 1/2"	2M	A
S8DGAL-2M	BST	.120 Plain Shank, Galvanized	8d - 2 1/2"	2M	Y
S8DRGAL	BST	.120 Ring Shank, Galvanized	8d - 2 1/2"	2M	A
S8DSS	BST	.120 Plain Shank, Stainless	8d - 2 1/2"	2M	A
S10D	BST	.120 Plain Shank, Coated	10d - 3"	2M	A
S10D131	BST	.131 Plain Shank, Coated	10d - 3"	2M	A
S10DGAL	BST	.120 Plain Shank, Galvanized	10d - 3"	2M	A
S10DRGAL	BST	.120 Ring Shank, Galvanized	10d - 3"	2M	A
S10DSGAL	BST	.120 Screw Shank, Galvanized	10d - 3"	2M	A
S10DSS	BST	.120 Plain Shank, Stainless	10d - 3"	2M	A
S12D-FH	BST	.120 Plain Shank, Coated	12d - 3 1/4"	2M	Y
S12D131	BST	.131 Plain Shank, Coated	12d - 3 1/4"	2M	A
S12DGAL-2M	BST	.120 Plain Shank, Galvanized	12d - 3 1/4"	2M	Y
S12DSGAL	BST	.120 Screw Shank, Galvanized	12d - 3 1/4"	2M	A
S12DSS	BST	.120 Plain Shank, Stainless	12d - 3 1/4"	2M	A
S16D131	BST	.131 Plain Shank, Coated	16d - 3 1/2"	2M	A
S16D131GAL	BST	.131 Plain Shank, Galvanized	16d - 3 1/2"	2M	A
S20D131	BST	.131 Plain Shank, Coated	20d - 4"	2M	A

These tools use the above nails



Additional tools:

- Bostitch N16
- Bostitch N86S
- Bostitch N70S
- Bostitch N70SB

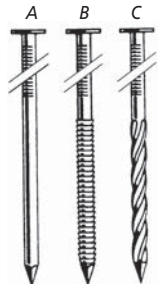

A - Plain Shank
B - Ring Shank
C - Screw Shank

22° RH Framing Nails Fit:

- Airy ABL-8290
- Astro RHS921
- Bostitch N90RHN
- Bostitch N95RHN
- Campbell NS2090
- Duo-Fast CN137
- Duo-Fast CN350
- Duo-Fast CN350B-SH
- Duo-Fast SNP83
- Fasco R5C-RHN-20-90SS-CT
- Hitachi NR83A
- Hitachi NR90AC
- Makita AN8300
- Max CN80
- Max SN90
- Paslode 5325 SRH
- Paslode 5350 SRN-20
- Paslode 5454
- Porter Cable FR350
- Senco SN60
- Senco SN65
- Senco SN65C
- Senco 702XP

Collated Nails

ProStrip™ Round Drive Framing Nails

Paper Collated Strip Nails

Paslode's ProStrip paper tape collated nails provide high holding power and ease of drive. Nail strip will not break when dropped and will not deteriorate in wet weather. Also, no collation material is left on the job site. Paper collation is driven into the wood, reducing flagging.



Item #	Code	Size	Gauge	Shank	Finish	Box	Stock*
650014-3M	PAS	1½"	.148	Smooth	Galvanized	3M	Y
650381-2M	PAS	2"	.113	Ring	Galvanized	2M	Y
650237-5M	PAS	2¾"	.113	Smooth	Brite	5M	Y
650238-5M	PAS	2¾"	.113	Ring	Brite	5M	Y
650383-2M	PAS	2¾"	.113	Ring	Galvanized	2M	Y
650382-2M	PAS	2¾"	.113	Smooth	Galvanized	2M	Y
650385-2M	PAS	3"	.120	Ring	Galvanized	2M	Y
650236-2.5M	PAS	3"	.120	Smooth	Brite	2.5M	Y
650210-2.5M	PAS	3"	.131	Smooth	Brite	2.5M	Y
650387-2M	PAS	3"	.131	Ring	Galvanized	2M	Y
650239-2.5M	PAS	3¼"	.131	Smooth	Brite	2.5M	Y
650388-2M	PAS	3¼"	.131	Smooth	Galvanized	2M	Y

These tools use the above nails



Paslode
IMCT



Paslode
F-350S

STANLEY BOSTITCH

15° Round Head Framing Nails



Coated Wire Coil Nails

Item #	Code	Size	Gauge	Description	Box	Stock*
C10P120D-2.7M	BST	3"	.120	Smooth Shank	2.7M	Y

These tools use the above nails:

- Bostitch N80CB
- Bostitch N89C
- Bostitch N100C
- Duofast CNW-75
- Hitachi NV83A
- Makita AN901
- Paslode F275C/P275C
- Paslode F325C/P325C
- Porter Coil350



30° Offset Round Head Framing Nails & Fuel Combo Pack

Paper Collated Strip Nails

Combo pack includes one Quicklode™ fuel cell, two fuel cell adapters and 1,000 nails.

- Each combo pack includes two fuel cell adapters that allow the fuel cell to work with any Paslode framing nailer
- PowerBoost™ black tip coating drives nails deeper into tough lumber
- Code recognized offset full nail head
- Fuel cell drives over 1,000 nails

Item #	Code	Size	Gauge	Shank	Finish	Box	Stock*
650522-1M	PAS	2¾"	.113	Smooth	Brite	1M	Y
650523-1M	PAS	2¾"	.113	Ring	Brite	1M	Y
650526-1M	PAS	2¾"	.113	Ring	Galvanized	1M	Y
650524-1M	PAS	3"	.120	Smooth	Brite	1M	Y
650527-1M	PAS	3"	.120	Ring	Galvanized	1M	Y
650535-1M	PAS	3¼"	.131	Smooth	Galvanized	1M	Y

We Rent Air Nailers,
Staplers & Accessories

CALL OUR
RENTAL DEPARTMENT
FOR RATES!

*Y = stock item; A = readily available by order

Collated Nails



PROFIT
PROFESSIONAL FIT

15° Round Head Framing Nails

Coated Wire Coil Nails

Item #	Code	Size	Gauge	Description	Box	Stock*
614110	NN	1 3/4"	.099	Drive Screw	9M	A
616633-3M	NN	2"	.113	Smooth	3M	Y
614130	NN	2"	.099	Drive Screw	9M	A
614131	NN	2"	.099	Drive Screw	4.5M	A
615130	NN	2"	.113	Drive Screw	9M	A
615131	NN	2"	.113	Drive Screw	4.5M	A
616433-3M	NN	2"	.113	Ring Shank	3M	Y
614140	NN	2 1/4"	.099	Drive Screw	9M	A
614141	NN	2 1/4"	.099	Drive Screw	4.5M	A
615140	NN	2 1/4"	.113	Drive Screw	9M	A
615141	NN	2 1/4"	.113	Drive Screw	4.5M	A
616653	NN	2 3/8"	.113	Smooth	3M	A
616453-3M	NN	2 3/8"	.113	Ring Shank	3M	Y
634151-3M	NN	2 3/8"	.113	Ring Shank, Galvanized	3M	Y
614150	NN	2 1/2"	.099	Drive Screw	9M	A
614151	NN	2 1/2"	.099	Drive Screw	4.5M	A
615150	NN	2 1/2"	.113	Drive Screw	9M	A
616670	NN	3"	.131	Smooth	2.5M	A
616673-2.5M	NN	3"	.120	Smooth	2.5M	Y
615170	NN	3"	.120	Drive Screw	2.5M	A
616473	NN	3"	.121	Ring Shank	3M	A
616690	NN	3 1/4"	.120	Smooth	2.5M	A
616693-2.5M	NN	3 1/4"	.131	Smooth	2.5M	Y
615190	NN	3 1/4"	.120	Drive Screw	2.5M	A
634181-2.5M	NN	3 1/4"	.120	Ring Shank, Galvanized	2.5M	Y

15° RH Framing Nails Fit:

- Atro RHC700
- Atro RHC900
- Atro ROL185
- Bea T701
- Bostitch N65CP
- Bostitch N70C
- Bostitch N80C
- Bostitch N86C
- Bostitch N100C
- Duo-Fast CNW75
- Fasco F5C CN15W65
- Fasco F5C CN15W90
- Hilti RC 31148
- Hitachi NV65AC
- Hitachi NV83A
- Max CN70
- Max CN80
- Paslode 3250/HSF
- Paslode 4275/CN70
- Paslode 5325/CN80
- Senco SCN300
- Senco SCN60
- Senco SCN65
- Stan-Tech SDCN-12B-1



Collated Fastener Tubs

Item #	Code	Size	Gauge	Description	Box	Stock*
<i>21° Plastic Round Head</i>						
GR04HG1M	GPR	2"	.113	HG Ring	1M	Y
GR071M	GPR	2 3/8"	.113	CTD Smooth	1M	Y
GR08R1M	GPR	2 3/8"	.113	CTD Ring	1M	Y
GR08RHG1M	GPR	2 3/8"	.113	HG Ring	1M	Y
GR3011M	GPR	3"	.120	CTD Smooth	1M	Y
GR408HG1M	GPR	3"	.120	HG Ring	1M	Y
GR0141M	GPR	3"	.131	CTD Smooth	1M	Y
GR033HG1M	GPR	3"	.131	HG Smooth	1M	Y
GR0241M	GPR	3 1/4"	.131	CTD Smooth	1M	Y
GR034HG1M	GPR	3 1/4"	.131	HG Smooth	1M	Y
<i>30° Offset Round Head Paper Tape</i>						
GRP6RHGH1	GPR	2"	.113	HG Ring	1M	Y
GRP8H1	GPR	2 3/8"	.113	CTD Smooth	1M	Y
GRP8RH1	GPR	2 3/8"	.113	CTD Ring	1M	Y
GRP8RHGH1	GPR	2 3/8"	.113	HG Ring	1M	Y
GRP10H1	GPR	3"	.120	CTD Smooth	1M	Y
GRP10RHGH1	GPR	3"	.120	HG Ring	1M	Y
GRP10ZH1	GPR	3"	.131	CTD Smooth	1M	Y
GRP10ZHGH1	GPR	3"	.131	HG Smooth	1M	Y
GRP12ZH1	GPR	3 1/4"	.131	CTD Smooth	1M	Y
GRP12ZHGH1	GPR	3 1/4"	.131	HG Smooth	1M	Y
<i>28° Offset Round Head Wire Weld</i>						
GRW8H1	GPR	2 3/8"	.113	CTD Smooth	1M	A
GRW8RH1	GPR	2 3/8"	.113	CTD Ring	1M	A
GRW8RHGH1	GPR	2 3/8"	.113	HG Ring	1M	A
GRW10RHGH1	GPR	3"	.120	HG Ring	1M	A
GRW12H1	GPR	3 1/4"	.120	CTD Smooth	1M	A
GRW12ZH1	GPR	3 1/4"	.131	CTD Smooth	1M	A
GRW16ZH1	GPR	3 1/2"	.131	CTD Smooth	1M	A
<i>15° Coil Roofing</i>						
GRCR3TRC	GPR	1 1/4"	.131	—	600	A
<i>15° Wire Siding</i>						
GRC7R92G1	GPR	2 3/16"	.092	EG Ring	1M	Y
GRC7R9SST	GPR	2 3/16"	.092	304SS RS White	1.2M	Y

*Y = stock item; A = readily available by order

Collated Nails



PROFIT
PROFESSIONAL FIT

15° Round Head Roofing Nails

Wire Coil Nails

Item #	Code	Size	Gauge	Description	Box	Stock*
611050	NN	1"	.120	Galvanized	7.2M	A
611070-7.2M	NN	1¼"	.120	Galvanized	7.2M	A
611090-7.2M	NN	1½"	.120	Galvanized	7.2M	Y
611110-7.2M	NN	1¾"	.120	Galvanized	7.2M	Y

These Fit:

- Atro RHC700
- Atro RHC900
- Atro ROL185
- Bea T701
- Bostitch N65CP
- Bostitch N70C
- Bostitch N80C
- Bostitch N86C
- Bostitch N100C
- Duo-Fast CNW75
- Fasco F5C CN15W65
- Fasco F5C CN15W90
- Hilti RC 31148
- Hitachi NV65AC
- Hitachi NV83A
- Max CN70
- Max CN80
- Paslode 3250/HSF
- Paslode 4275/CN70
- Paslode 5325/CN80
- Senco SCN300
- Senco SCN60
- Senco SCN65
- Stan-Tech SDCN-12B-1

Full Round Head Roofing Nails

Wire Coil Nails



Item #	Code	Size	Gauge	Description	Box	Stock*
M003104-7.2M	SEN	1¼"	.120	Galvanized	7.2M	Y
M003105-7.2M	SEN	1½"	.120	Galvanized	7.2M	Y

CAN'T FIND THE
PRODUCT YOU NEED?

CALL US!

HITACHI

Full Round Head Siding Nails

Plastic Sheet Hot Dipped Galvanized Wire Coil Nails



Item #	Code	Size	Gauge	Description	Box	Stock*
13305-6M	HIT	1¾"	.092	Ring Shank	6M	Y
13385-4.8M	HIT	2¼"	.092	Ring Shank	4.8M	Y

Full Round Head Siding Nails

Plastic Sheet Electro Galvanized Wire Coil Nails



Item #	Code	Size	Gauge	Description	Box	Stock*
13320-4.8M	HIT	2¼"	.092	Ring Shank	4.8M	Y
13321-4.8M	HIT	2¼"	.092	Smooth Shank	4.8M	Y

Full Round Head Siding Nails

Stainless Steel Wire Coil Nails



Item #	Code	Size	Gauge	Description	Box	Stock*
13327-2.4M	HIT	2¼"	.090	Ring Shank	2.4M	Y
13356-3.6M	HIT	2½"	.090	Ring Shank	3.6M	Y



These nails fit Hitachi NV65AH Framing Nailer

*Y = stock item; A = readily available by order

Staples for Air Tools

18 Gauge 1/4" Crown Finish Staples Galvanized Finish

Item #	Code	Size	Qty	Stock*
L08BAB	SEN	1/2"	10M	A
L10BABN-5M	SEN	5/8"	5M	Y
L11BAB-5M	SEN	3/4"	5M	Y
L12BAB	SEN	7/8"	5M	A
L13BABN-5M	SEN	1"	5M	Y
L14BAB-5M**	SEN	1 1/8"	5M	Y
L15BAB-5M**	SEN	1 1/4"	5M	Y
L17BAB-5M**	SEN	1 1/2"	5M	Y

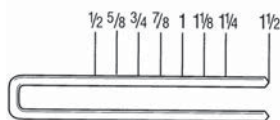

**Does not fit AccuSet A100LS, A2N125, Craftsman 18406 and Porter-Cable NS100

These tools use the above staples



Senco
SLS20-L

Senco
SKS-L

Hitachi
N3804AB



Porter-Cable
NS100

Porter-Cable
NS150

Additional tools:

- Senco SLS25-L
- AccuSet A100LS
- AccuSet A150LS
- AccuSet A2N125
- Craftsman 18406
- Craftsman 18367
- Duo-Fast KN1848



16 Gauge 7/16" Crown Sheathing Staples Galvanized Finish

Item #	Code	Size	Qty	Stock*
N11BAB	SEN	3/4"	10M	A
N12BAB	SEN	7/8"	10M	A
N13BAB-5M	SEN	1"	5M	Y
N14BAB-10M	SEN	1 1/8"	10M	Y
N15BAB-10M	SEN	1 1/4"	10M	Y
N17BAB-10M	SEN	1 1/2"	10M	Y
N19BAB-10M	SEN	1 3/4"	10M	Y
N21BAB-10M	SEN	2"	10M	Y

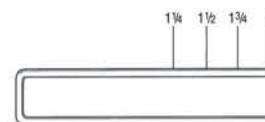

These tools use the above staples

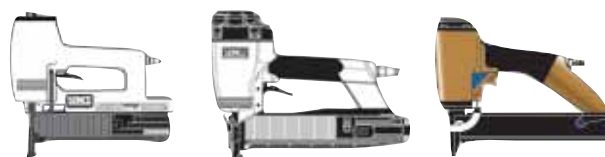

Senco
M2

Senco
SNS45

Duo-Fast
DS-7664



Hitachi
5008AA/AB

Porter-Cable
MS200

Senco
SNS40

Additional tools:

- Senco M1
- Senco SNS50

16 Gauge 1" Crown Roofing Staples Galvanized Finish

Item #	Code	Size	Qty	Stock*
P10BAB	SEN	5/8"	10M	A
P11BAB-10M	SEN	3/4"	10M	Y
P12BAB	SEN	7/8"	10M	A
P13BAB-10M	SEN	1"	10M	Y
P15BAB-10M	SEN	1 1/4"	10M	Y
P17BAB-10M	SEN	1 1/2"	10M	Y
P19BAB-5M	SEN	1 3/4"	5M	Y
P21BAB-5M	SEN	2"	5M	Y

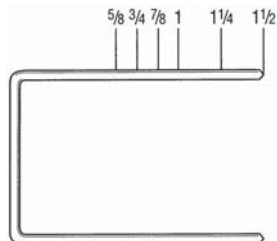

These tools use the above staples

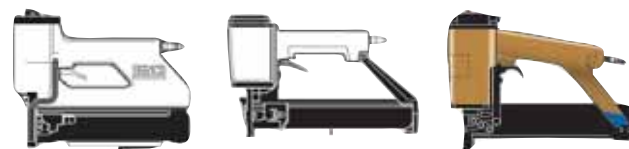

Senco
MW

Senco
SPS

Duo-Fast
KW-1748



Duo-Fast
RS-1748



Hitachi
N3824A

Additional tools:

- Senco PW

*Y = stock item; A = readily available by order

Staples for Air Tools

15 Gauge $\frac{7}{16}$ " Crown Staples

Galvanized Finish

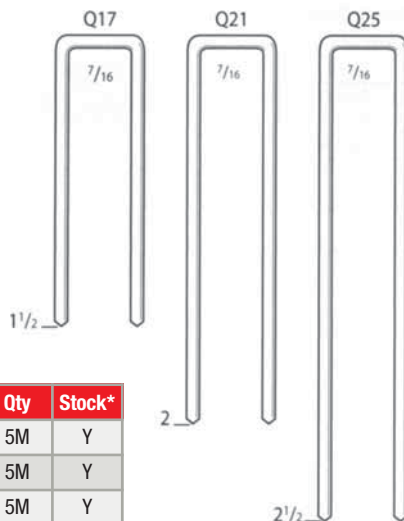

Item #	Code	Size	Qty	Stock*
Q17BAB-5M	SEN	1 1/2"	5M	Y
Q21BAB-5M	SEN	2"	5M	Y
Q25BAB-5M	SEN	2 1/2"	5M	Y



16 Gauge $\frac{1}{2}$ " Crown Staples

Galvanized Finish



Item #	Code	Size	Qty	Stock*
OT2695-10.5M	PAS	1 1/2"	10.5M	Y
OT2250-9M	PAS	1 3/4"	9M	Y

15 1/2 Gauge $\frac{1}{2}$ " Crown Floor Staples

Galvanized & Coated Finish

Item #	Code	Size	Qty	Stock*
BCS1512-5M	PAS	1 1/2"	5M	Y
BCS1514	PAS	1 3/4"	5M	A
BCS1516-5M	PAS	2"	5M	Y

For use in
Bostitch
MIIFS



18 Gauge $\frac{7}{32}$ " Crown Staples

Galvanized



Item #	Code	Size	Qty	Stock*
SX50351-1/8G	BOS	1 1/8"	3M	Y

For use in
Bostitch
EHF1838K



Staples for Hand Tools



These Arrow
Fastener tools
use T50 staples



T50® Staples

• $\frac{3}{8}$ " crown width x .050 wire

Item #	Code	Size	Staples/ Pack	Stock*
T5014	ARR	1/4" - 6mm	1,250	Y
T50516	ARR	5/16" - 8mm	1,250	Y
T5038	ARR	3/8" - 10mm	1,250	Y
T5012	ARR	1/2" - 12mm	1,250	Y
T50916	ARR	9/16" - 14mm	1,250	A
T50CT	ARR	Ceiltile™ 17/32" - 13mm	1,250	A



P35™ & P35S™ Staples

for use in P35™
& P35S™ Pliers



Item #	Code	Size	Staples/ Pack	Stock*
P3514	ARR	1/4" - 6mm	5M	Y
P3538	ARR	3/8" - 10mm	5M	Y

Duo-Fast 1/2" Wide Crown Staples

for Duo-Fast models CS-5000, EWC-5018A, HT-550 Classic, SureShot® 5020 DLA, SureShot® 5020 S, SureShot® 5020



Item #	Code	Size	Gauge	Description	Box	Stock*
5010D-5M	DUO	5/16"	20	Galvanized	5M	Y

Duo-Fast $\frac{3}{16}$ " Narrow Crown Staples

for Duo-Fast models CarpetPro, SureShot® 5424

Item #	Code	Size	Gauge	Description	Box	Stock*
5018D-5M	DUO	3/16"	20	Galvanized	5M	Y

*Y = stock item; A = readily available by order