

RISER CLAMPS



FUNCTION: Designed for supporting and stabilizing vertical pipe runs. The PVC coating on Fig. 553 protects the pipe from the metal surface of the clamp. This product is not intended for use with hanger rods. Clamp is designed for standard iron pipe O.D. and must be considered when sizing other types of piping.

APPROVALS: Underwriters' Laboratories Listed in the U.S. (UL) and Factory Mutual Approved for sizes 3/4" (20mm) to 8" (200mm) only. Complies with Federal Specifications A-A-1192A (Type 8) and Manufacturers' Standardization Society ANSI/SP-69 and SP-58 (Type 8).

MATERIAL: Low carbon steel

ORDERING: Specify pipe size and figure number.

Fig. 550, 551 & 553 RISER CLAMP

Fig. 550* PLAIN

Fig. 551 ELECTRO-GALVANIZED

Fig. 553 PLAIN WITH PVC COATING

*Available in stainless steel.

To order, specify 304 or 316 and add suffix SS to figure number.

Price on request.

Pipe Size		B	C	Bolt Size	Max. Rec. Load		Wt. Each			
					lbs.	kN	lbs.	kg		
1/2	(15)	9	(228.60)	2 1/2	(63.50)	3/8 x 1 1/4	220	(0.98)	1.05	(.48)
3/4	(20)	8 7/8	(225.43)	2 3/8	(60.33)	3/8 x 1 1/4	220	(0.98)	1.05	(.48)
1	(25)	8 3/4	(222.25)	2 1/4	(57.15)	3/8 x 1 1/4	220	(0.98)	1.05	(.48)
1 1/4	(32)	9 1/4	(234.95)	2 3/4	(69.85)	3/8 x 1 1/4	250	(1.11)	1.10	(.50)
1 1/2	(40)	10	(254.00)	2 3/4	(69.85)	3/8 x 1 1/4	250	(1.11)	1.17	(.53)
2	(50)	10 1/4	(260.35)	3 1/2	(88.90)	3/8 x 1 1/4	300	(1.33)	1.20	(.54)
2 1/2	(65)	11 1/8	(282.58)	3 3/4	(95.25)	3/8 x 1 1/2	400	(1.78)	1.89	(.86)
3	(80)	11 3/4	(298.45)	4 5/8	(117.48)	3/8 x 1 1/2	500	(2.22)	1.99	(.90)
3 1/2	(90)	12 1/2	(317.50)	5 1/4	(133.35)	3/8 x 1 1/2	600	(2.67)	2.17	(.98)
4	(100)	13	(330.20)	6	(152.40)	1/2 x 1 3/4	750	(3.34)	2.21	(1.00)
5	(125)	14 1/4	(361.95)	6 1/2	(165.10)	1/2 x 1 3/4	1500	(6.67)	3.24	(1.47)
6	(150)	15 3/8	(390.53)	7 3/4	(196.85)	1/2 x 1 3/4	1600	(7.12)	3.89	(1.76)
8	(200)	18 1/2	(469.90)	8 7/8	(225.43)	5/8 x 2	2500	(11.12)	7.60	(3.45)
10	(250)	20 1/2	(520.70)	12	(304.80)	5/8 x 2	2500	(11.12)	11.10	(5.03)
12	(300)	22 1/2	(571.50)	14	(355.60)	5/8 x 2 1/2	2700	(12.01)	16.50	(7.48)
14	(350)	25 1/8	(638.18)	16	(406.40)	5/8 x 3	2700	(12.01)	17.70	(8.03)
16	(400)	26 1/4	(666.75)	18 5/8	(473.08)	3/4 x 3 1/2	2900	(12.90)	30.40	(13.79)
18	(450)	27 7/8	(708.03)	20 3/4	(527.05)	3/4 x 3 1/2	2900	(12.90)	33.30	(15.10)
20	(500)	30	(762.00)	22 3/8	(568.33)	3/4 x 3 1/2	2900	(12.90)	36.30	(16.47)
24	(600)	35	(889.00)	24 1/2	(622.30)	7/8 x 3 1/2	2900	(12.90)	48.68	(22.08)
30	(750)	42 3/8	(1076.33)	29 1/2	(749.30)	7/8 x 3 1/2	2900	(12.90)	60.16	(27.29)

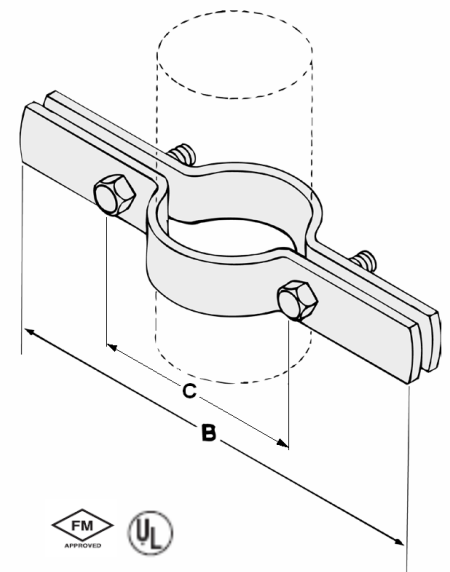

Installation practice for Model 550 Riser Clamps

When possible the clamp should be placed under a coupling, hub or welded lugs on steel pipe. Bolt torques should be per industry standards.

Recommended Torque For Pipe Clamp Hardware						
Bolt Size	1/4"-20	5/16"-18	3/8"-16	1/2"-13	5/8"-11	3/4"-10 & Larger
ft/lbs	6	11	19	50	65	75
N/m	(8)	(15)	(26)	(68)	(88)	(102)

Unless otherwise specified, all dimensions on drawings and in charts are in inches and dimensions shown in parentheses are in millimeters.