

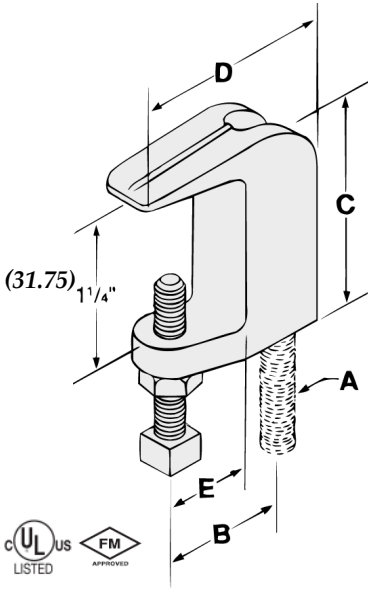

# BEAM CLAMPS

**Fig. 360**  
**WIDE MOUTH**  
**BEAM CLAMP**



**FUNCTION:** Designed for attaching hanger rod to the top flange of a beam or bar joist, where the flange thickness does not exceed 1 1/4 inches (31.75mm). The open U design permits rod adjustment.

**APPROVALS:** Underwriters' Laboratories Listed in the U.S. (UL), Canada (CUL), and Factory Mutual Approved for rod sizes 3/8" and 1/2" only. Complies with Federal Specifications A-A-1192A (Type 19) and Manufacturers' Standardization Society ANSI/SP-69 and SP-58 (Type 19). (Approvals are only for Fig. 360 with locknut).

**MATERIAL:** Malleable iron with hardened steel cup point set screw

**FINISH:** Plain or electro-galvanized

**ORDERING:** Specify rod size, finish and figure number.

Set Screw Torque		
Nominal Thread Size	3/8	
Rec. Torque	in-lbs	60
	N-m	(6.8)

Caution should be taken not to over tighten the set screw

*Note: When a torque wrench is unavailable, the setscrew should be tightened so it contacts the I-beam and then an additional 1/4 to 1/2 turn added.*

Rod Size A	B		C		D		E		Max. Pipe Size	Max. Rec. Load		Wt. Each	
	in	(mm)	in	(mm)	in	(mm)	in	(mm)		lbs.	kN	lbs.	kg
3/8	1	(25.40)	1 7/8	(47.63)	1 5/8	(41.28)	1/2	(12.70)	4 (100)	400	(1.78)	.37	(.17)
1/2	1	(25.40)	1 7/8	(47.63)	1 5/8	(41.28)	1/2	(12.70)	8 (200)	500	(2.22)	.35	(.16)
5/8	1 3/8	(34.93)	2 5/16	(58.74)	2 1/4	(57.15)	3/4	(19.05)	5 (125)	850	(3.78)	.74	(.34)
3/4	1 1/2	(38.10)	2 3/8	(60.33)	2 3/8	(60.33)	3/4	(19.05)	6 (150)	900	(4.00)	.87	(.39)

Unless otherwise specified, all dimensions on drawings and in charts are in inches and dimensions shown in parentheses are in millimeters.